

## Site Preparation Document F1832

---

# Instructions and Sign-off





**Summa nv**  
Rochesterlaan 6  
8470 Gistel  
Belgium

**Document history:**

**Publication date :**

07/01/2021

01/04/2021

**Release version**

Publication Document

integration safety precautions

**Notice**

Due to continuing research and product improvements, Summa reserves the right to modify the information contained in this document at any time without prior notice. Unauthorized copying, modification, distribution or display is prohibited. All rights reserved.

Copyright © Summa

# F SERIES™

---

## Document Sections

This document is divided into two sections.

- The first section provides the information needed to prepare the physical location for the installation of the F-Series Flatbed Cutter. Also included are transportation and connection specifications.
- The second section contains the signature and information pages. This will give an overview of the installation site, system configuration and workflow at the end user. This information will facilitate the installation.

## Section 1: Site Preparation Document



**Note:** Before the installation can be scheduled, the customer location must be prepared. The customer should check and mark all points in the checklist and fill out where necessary and return this signed document to the installation engineer.



**Note:** There exists also an installation completion document. It is recommended to use this document, also after that the flatbed is installed. Always make sure there is a copy of the document (completely filled in) for each party.



**CAUTION:** The amount of time the engineer will spend on the site for the installation is limited. Proper site preparation is crucial to the success of the installation. Any delay due to missing machinery, options, accessories, people or other installation requirements will be added to the onsite-time and will be charged supplemental.

## Preparation before installing the machine

Prior to installation of the flatbed cutter a couple of things need to be prepared in order to facilitate a smooth installation. The installation place also needs to meet certain requirements. In section 2 of this document there is a checklist that must be checked before the arrival of the machine.

## Shipping, Arrival and Unpacking



Figure 1 All Crates

### The machine is delivered in 5 crates

There are several options for unloading and transporting the crates. Use the info below to determine the correct lift capacity of the transportation vehicles.

F1832 (Packed)					
	Length (mm)	Width (mm)	Height (mm)	Weight (kg)	Tare Weight (kg)
Crate 1	2450	980	1090	470	200
Crate 2	4030	980	1090	870	250
Crate 3	1980	1180	890	415	150
Crate 4	1980	1180	890	325	150
Crate 5	1980	1180	890	300	150

#### Forklift:

When using the forklift, crate 2 can only be transported in width.

- Fork length: Min 1200mm
- Adjustable fork width: from 1050mm to 1400mm or more.

#### Pallet truck(s) (optional but recommended):

It is mandatory to use 2 pallet trucks at the same time when moving crate 2 in length

- Pallet truck min length: 1m

The width of the outside and inside corridor doorways depend on how the crates are moved. Check the crate dimensions table above to know the exact width needed for the doorways/corridors. Take in account a minimum of 10cm extra space.

#### Points of attention:

- Avoid stairs during unpacking and the installation
- Keep about 5 or 6m room at one side of the machine for installation

## Floorplan

Use the floorplan to determine if the installation area and/or positioning is suited for the machine.

A solid and level concrete surface is recommended, preferably antistatic.

Wooden frames/floors/constructions are not suitable.

The height difference over the whole installation area should not be more than 3cm.

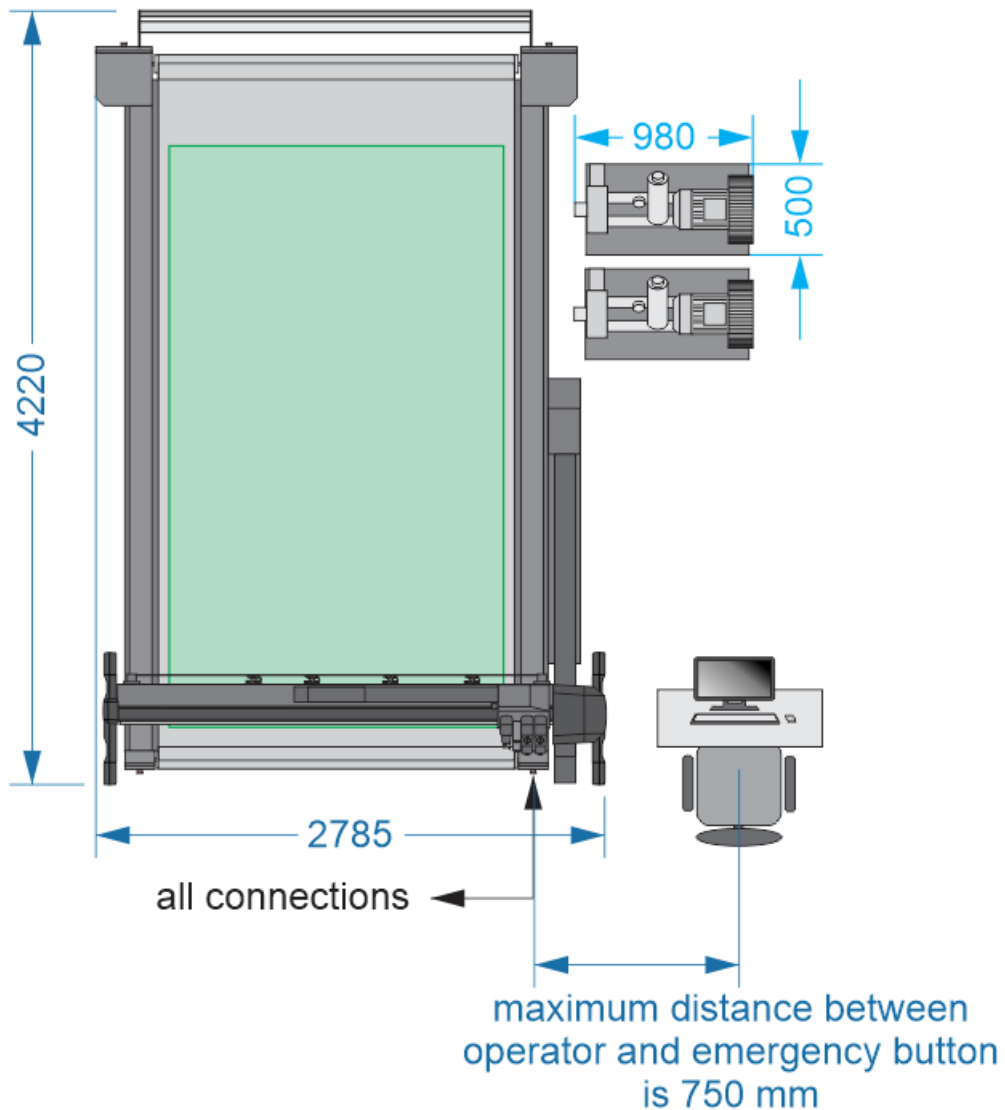

Figure 2 Floorplan F1832 Top View

### Optional Router System:

#### Minimum Ceiling Height:

- With gantry: 2835mm (+250mm to facilitate install)
- With ceiling bracket: 2700mm

**NOTE:** Ceiling needs to be sturdy enough to hold the weight of the rail and vacuum hose

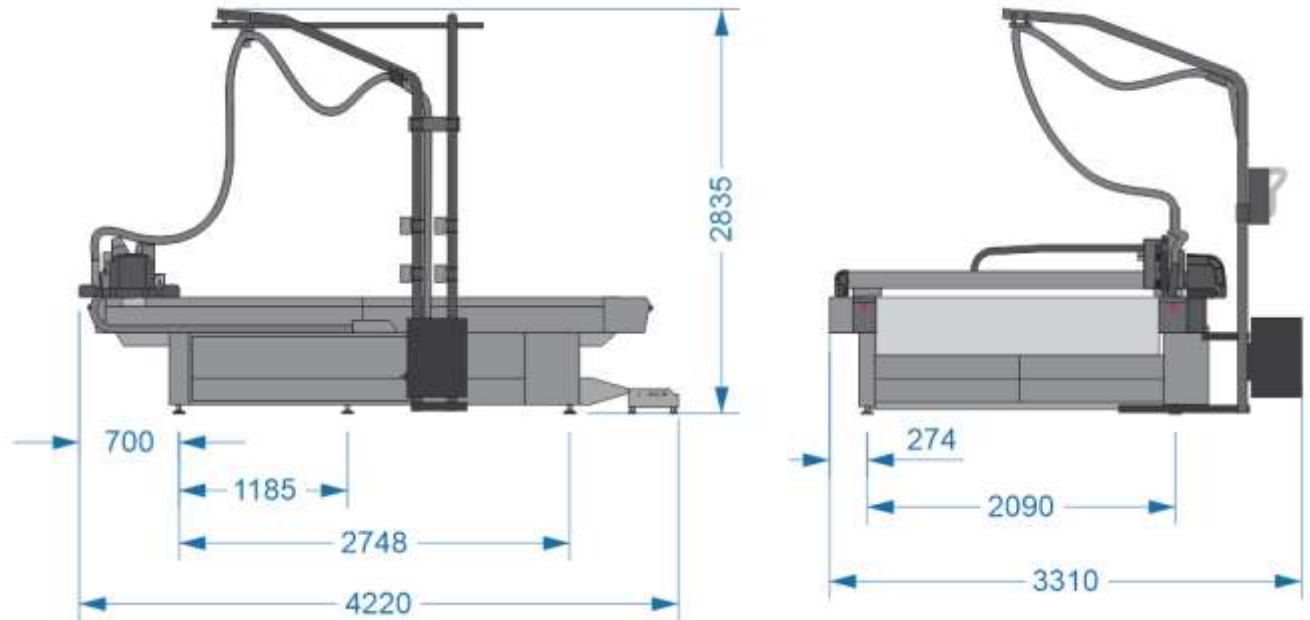

Figure 3 Floorplan F1832 Right Side View and Front View

### Connections

The flatbed cutter has three connections marked with 'All Connections' on the figure above.

#### USB Connection

The flatbed cutter is delivered with a 3 meter USB cable and a 0.5m extension USB cable for connection to the PC.

#### DO NOT USE:

- A USB cable longer than 3.5m
- (Powered) USB Hubs
- Extension cables

Do not forget to provide power and a network connection for the computer.

## Electrical connection

The electrical cable and wall socket are **NOT INCLUDED** with the flatbed cutter. This should be provided by the end user.

The wall socket and cable plug need to be IEC60309 standard.  
The connection to the mains may also be done with an electric wall box.

Power Requirements (including Summa's standard vacuum set):

- Or: 3x 208V + N ,60 Hz, max 30A
- Or: 3 x 400V + N , 50Hz, max 30A
- Or: 3 x 230V, 50Hz, max 30A

Power Cable:

- Length: Distance between machine and socket + 2m
- 3 or 4 core + ground (according to grid voltage)
- Overall diameter: between 9 mm (0.36") and 17 mm (0.67")
- **Europe:** The section of each core should be at least 4 mm<sup>2</sup> (3 X 400V + N and 3 X 230V). If the cable is longer then 25m, then the section has to be at least 6 mm<sup>2</sup>.
- **North America:** The diameter of each core should be at least AWG 10 with MTW rating for the North American market (3 x 208V + N).

External overcurrent protection 208Y/120V, 40A max, 10 kA interrupting capacity.



Figure 4 IEC60309 Plug and Socket reference picture



**CAUTION:** Be sure to check the regional electrical requirement for the type of wall socket and plug and fuse for the wall socket or electrical wall box.

## Pneumatic connection

The pneumatic tube and connector are **NOT INCLUDED** with the flatbed cutter. This should be provided by the end user.

Pneumatic tube:

- $\varnothing$ 10mm
- Length: Distance between machine and compressor + 2m

Connector:

- 1:  $\varnothing$ 10mm connection for pneumatic tube
- 2: Thread for connection to compressor or quick coupler

Compressor:

- Without pneumatic tools/options:
  - 7 bar (100 PSI) @ 20 l/min (0.72 cfm)
- With HF Router option:
  - Particle Class 3
  - Water Class 4
  - Oil Class 3
- With POT:
  - 7 bar (100 PSI) @ 350 l/min (12.4cfm)
  - Class 4 ISO 8573-1 or additional air cleaner/dryer



Figure 5 Pneumatic Connector Reference Picture



## Requirements for router option

The router is an option that has to be installed by a technician. It involves both mechanical and electrical changes to the table.

Please check installation instructions of the router for minimum requirement.

## Vacuum cleaner for all router options

Currently Summa offers 2 types of vacuum cleaners:

- Metabo (small)
- Hercules (big)



**CAUTION:** The above mentioned vacuum cleaners Summa offers can only be used in Europe.

Type	3x400V + N , 50Hz	3 x 230V, 50Hz	3x 208V + N ,60 Hz	3x 208V ,50-60 Hz
Metabo	OK	OK	Cannot be used	Cannot be used
Hercules	OK	Extra socket <sup>(1)</sup>	Cannot be used	Cannot be used
3rd party	Max. 3000W	Max. 2400W or	Max 1500W <sup>(2)</sup> or	Max 1500W <sup>(2)</sup> or
		Max. 3000W with: Extra socket <sup>(1)</sup>	Max 2000W <sup>(2)</sup> with: Extra socket <sup>(1)</sup>	Max 2000W <sup>(2)</sup> with: Extra socket <sup>(1)</sup>

(1) Extra socket means that a secondary wall socket (single phase) needs to be provided for the vacuum cleaner.

(2) Specifications given for 110V vacuum cleaner.

Specifications for third party vacuum cleaners:

- Air Output (at fan): Min 3.000l/min (106 cfm)
- Vacuum: Min 230 hPa (mbar) (92 Inch of water)
- Hose diameter is 35 – 38mm (exact specifications of connection can be found on the internet under 'screw cuff a72-84V')

## Installation tools

Please consult the corresponding large F-Series installation manual for a complete list of the tools that are needed for the installation.

## System requirements

Dedicated PC or laptop with hardware components that are up to date with the today standards.

- **OS:** Windows 10
- **Screen:** Full HD

- **USB:** At least 1 free USB connection and an optional one (if remote has been ordered).



**CAUTION:** There are also other Windows **versions** available. For Europe, there exist the N edition and for South Korea, there exist the KN edition. If this edition is installed, then the media pack has to be installed also, otherwise there will be problems with the camera. To install media pack go to:  
<https://support.microsoft.com/en-us/help/3145500/media-feature-pack-list-for-windows-n-editions>



**CAUTION:** It is highly recommended to use a dedicated computer to connect to the table. If other programs and services not related to driving the table run, then they can take up too many resources so that the minimum system requirements will no longer suffice.

# F SERIES™

---

## Section 2: Signature pages

Complete the checklist and extra info.

If all this has been done, sign of the certification page.

### Checklist

- The delivery truck can unloaded and the crates can be moved inside
- Forklift or pallet truck(s) with the correct lift capacity will be available
- 3 people are required during setup of the chassis of the machine (2 people further on)
- Unobstructed path to installation area (steps, stairs, radiators,..)
- The installation area (will be) free. It is recommended mark this area on the floor
- The installation floor meets the requirements

All the necessary connections and the parts to connect them (choose 1 of the below):

- Are available and ready
- Will be prepared by a person with knowledge of the local power requirements and will be available during the installation

3 Phase power supply and type: \_\_\_\_\_

Compressor specifications: \_\_\_\_\_

- A dedicated PC is/will be ready for use and installation of the necessary programs to operate the cutter
- The future operator is available during the entire training
- The environment complies with the requirements for operating the machine

### Extra Info

Software used:

- Operating system: \_\_\_\_\_
- Designing: \_\_\_\_\_
- RIP: \_\_\_\_\_

Extra info or requests:

---



## Certification

---

I hereby certify that all site preparation tasks have been completed and the necessary parts/tools and people will be available during the install and training.

When all signature pages are completed, (photo)scan and mail them to [installations@summa.com](mailto:installations@summa.com).

Company name: \_\_\_\_\_

Name: \_\_\_\_\_

Date: \_\_\_\_\_

Signature: \_\_\_\_\_

## E Series: Safety precautions - Précautions de sécurité.

---



### Caution

These installation instructions are for use by qualified service personnel only.

Risk of electric shock.

Hazardous voltage present for up to 5 minutes after disconnection of power supply.

To reduce the risk of electric shock do not perform any servicing other than that contained in the operating instructions unless you are qualified to do so.

### Attention

Ces consignes d'installation doivent être uniquement employés par le personnel de service qualifié.

Risque de choc électrique.

Tension dangereuse présente jusqu'à 5 minutes après la coupure de l'alimentation.

Pour réduire le risque de choc électrique, ne pas effectuer des réparations autre que ceux contenus dans les instructions d'utilisation à moins que vous soyez qualifié pour le faire.

---



### Caution

Contains Class II laser. Do not stare into the beam.

Complies with CFR Title 21, Chapter I, Subchapter J, Sections 1010.2, 1010.3, 1040.10 and 1040.11 in effect at date of manufacture.

Caution: use of any controls, adjustments or procedures other than those specified herein may result in hazardous radiation exposure.

### Attention

Contient un laser de classe II. Ne regardez pas dans le faisceau.

Conforme au titre 21 du CFR, chapitre I, sous-chapitre J, sections 1010.2, 1010.3, 1040.10 et 1040.11 en vigueur à la date de fabrication.

L'emploi de contrôles, ajustements ou mise à l'essai autre que spécifiés peut provoquer une exposition dangereuse à des radiations.

---



### Caution

Sharp edges.

Touching the tools with bare hands may cause injury.

Do not touch.

### Attention

Présence d'arêtes vives.

Toucher les outils à mains nues peut provoquer des blessures.

Ne pas toucher.

---



### Caution

Moving parts.

Keep body parts out of the motion path.

### Attention

Parties mobiles.

Se tenir à l'écart de la zone de mouvement.

---



**Caution**

This equipment is not suitable for use in locations where children are likely to be present.  
This equipment is not intended for use by children.

Avoid touching the moving parts and entering the cutting area with the hands, clothing, jewelry or hair.  
Unplug this equipment when not used for an extended period of time.

**Attention**

Cet équipement ne convient pas à une utilisation dans des lieux susceptibles d'accueillir des enfants.  
L'équipement n'est pas destiné à être utilisé par des enfants. Cet équipement n'est pas un jouet.  
Évitez de toucher les pièces mobiles et de pénétrer dans la zone de découpe avec les mains, les vêtements, les bijoux et les cheveux.

Débrancher l'équipement lorsque celui-ci n'est pas utilisé pendant une période prolongée.



**Caution**

Hot surface.  
Do not touch marked parts.

**Attention**

Surface chaude.  
Ne touchez pas les pièces marquées.



**Warning**

Hearing protection should be worn in case of prolonged exposure to the noise of the vacuum pumps.  
Eye and/or hearing protection must be worn when using certain power tools.

**Attention**

Une protection auditive doit être portée en cas d'exposition prolongée au bruit des pompes à vide.  
Une protection oculaire et/ou auditive doit être portée lors de l'utilisation de certains outils de puissance.

Revised April 2, 2021