

Site Preparation Document for F3232

Instructions and Sign-off

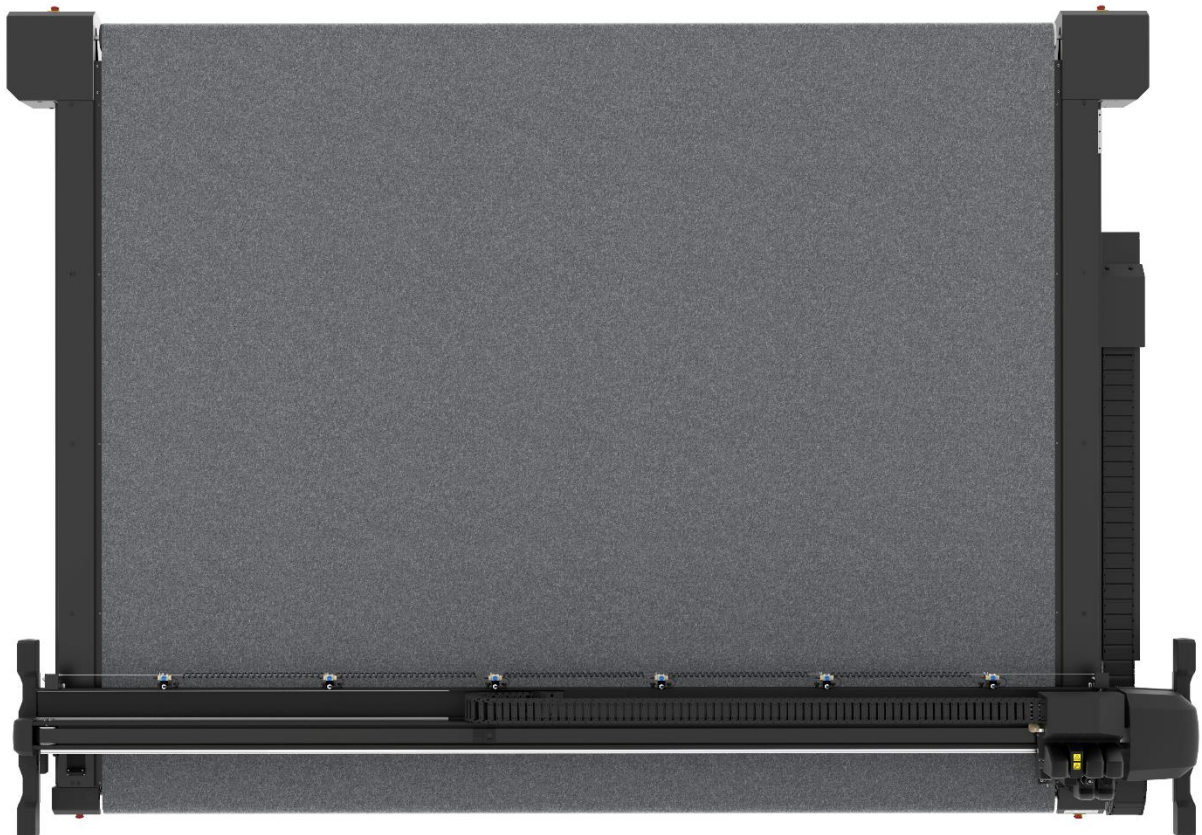



Version overview

Version	Date	Reason for modification	Author
001	12/02/2021	Original version	Sam B.
002	02/04/2021	Added safety precautions	Sam B.
003	23/08/2021	Layout and language revision	Astrid L.

Notice

Due to continuing research and product improvements, Summa reserves the right to modify the information contained in this document at any time without prior notice. Unauthorized copying, modification, distribution, or display is prohibited. All rights reserved.

Copyright © Summa



F SERIES™

1 CONTENTS OF THIS DOCUMENT

This document explains how to prepare the customer site for the installation of the F-Series Flatbed Cutter and gives information regarding transportation and connection. At the end of this document, official forms are included that provide an overview of the installation site, system configuration and end-user workflow. This information will facilitate the installation.

1	Contents of this document.....	3
2	Site Preparation.....	4
2.1	Shipping, Arrival and Unpacking	5
2.2	Floorplan	6
2.2.1	F3232 with Optional Router System:	7
2.3	Connections	7
2.3.1	USB Connection.....	7
2.3.2	Electrical connection	9
2.3.3	Pneumatic connection	10
2.4	Requirements for router option.....	11
2.4.1	Vacuum cleaner for all router options	11
2.5	Installation tools	11
2.6	System requirements.....	12
3	Pages for completion and signature.....	13
3.1	Preparational checklist	13
3.2	Extra Info.....	13
3.3	Certification.....	14
4	Safety precautions	15

2 SITE PREPARATION

Prior to installation of the flatbed cutter, a couple of things need to be prepared to ensure smooth installation. The site must also meet certain requirements, see the checklist on page 13.



NOTE: Before installation can be scheduled, the customer site needs to be prepared. The customer must check and tick all the points on the checklist (see p. 13), complete where necessary and return this document signed to the installation engineer.



NOTE: An installation completion document is available. We recommend using this document, also after the installation of the flatbed. Make sure each party has a copy of the completely filled-in document.



ATTENTION: The amount of time the engineer will spend on-site for the installation is limited. Proper site preparation is crucial for a successful installation. Any delay due to missing machinery, options, accessories, people, or other installation requirements will be added to the on-site time and will be charged extra.

2.1 Shipping, Arrival and Unpacking



Figure 1: All Crates

The machine is delivered in five crates. There are several options for unloading and transporting these crates. Use the table below to determine the correct lifting capacity of the transportation vehicles.

F3232 (Packed)					
	Length (mm)	Width (mm)	Height (mm)	Weight (kg)	Tare Weight (kg)
Crate 1	4560	1280	1090	800	250
Crate 2	4030	980	1090	800	200
Crate 3	1980	1180	1190	700	150
Crate 4	1980	1180	890	400	150
Crate 5	1980	1180	890	350	150

- Forklift:
 When using a forklift, crate 2 can only be transported in width.
 - Fork length: min 1200mm
 - Adjustable fork width: from 1050mm to 1400mm or more.
- Pallet truck(s) (optional but recommended):
 It is obligatory to use 2 pallet trucks at the same time when moving crates 1 and 2 in length
 - Pallet truck minimum length: 1m

The width of the outside and inside corridors/doorways depend on how the crates are transported. Check the crate dimensions table above to know the exact width needed for the doorways/corridors. Take in account a minimum of 10cm of extra space.

Points of attention:

- Avoid stairs during unpacking and installation.
- Keep 5m to 6m clear on one side of the machine to make it easier to work during installation.

2.2 Floorplan

Use the floorplan to determine if the installation area and/or positioning is suited for the machine.

- A solid and level concrete surface, preferably antistatic, is recommended.
- Wooden frames/floors/constructions are not suitable.
- The height difference over the entire installation area should not be more than 3cm.

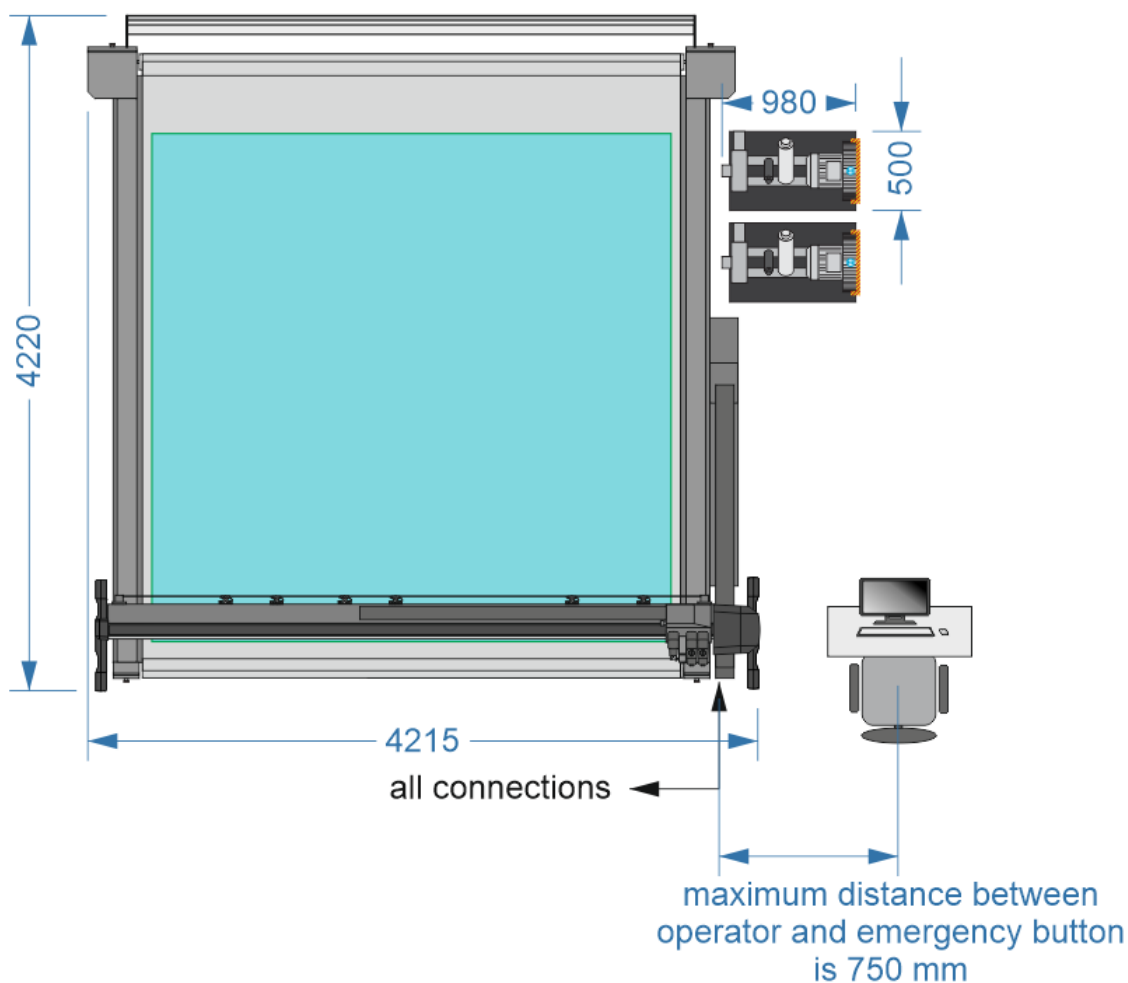

Figure 2: floorplan F3232 – top view

2.2.1 F3232 with Optional Router System:

Minimum ceiling height:

- With gantry: 2930mm (+ 250mm to facilitate installation)
- With ceiling bracket: 2750mm

NOTE: The ceiling needs to be sturdy enough to hold the weight of the rail and vacuum hose.

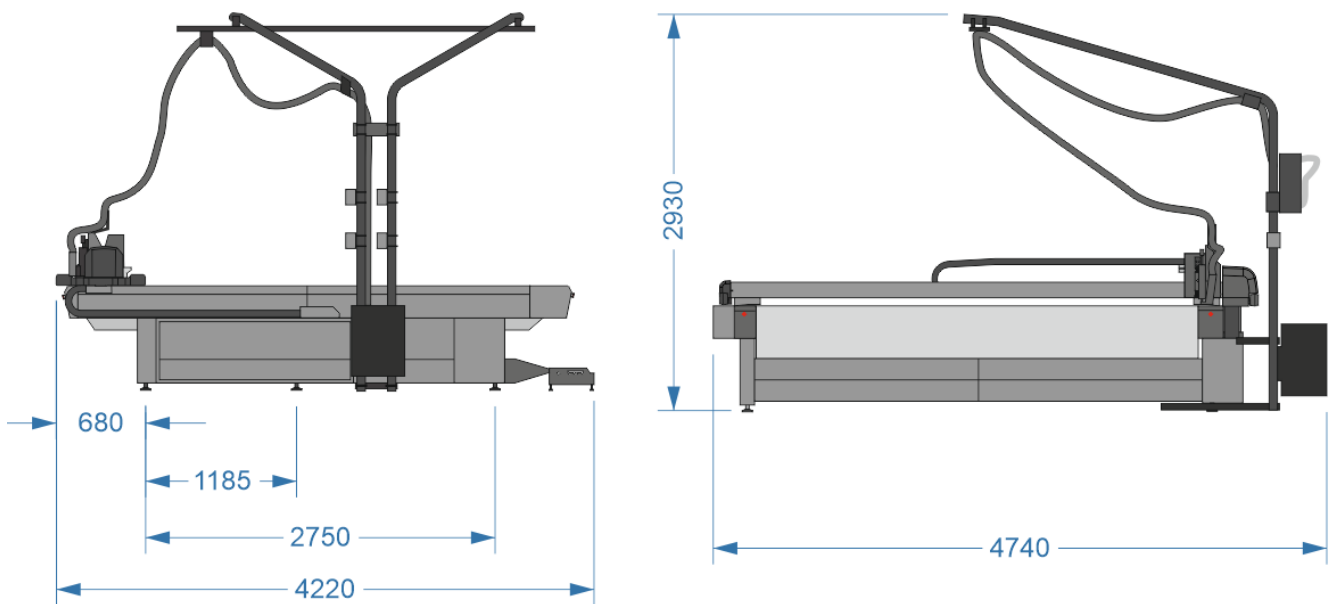

Figure 3: Floorplan F3232 with router – Right Side View and Front View

2.3 Connections

The flatbed cutter has three connections. Their location is marked with ‘all connections’ on the previous page.

2.3.1 USB Connection

The flatbed cutter is delivered with a 3-meter USB cable and a 0.5m extension USB cable for connection to the PC.

WHAT NOT TO USE?

- A USB cable longer than 3.5m
- (Powered) USB hubs
- Extension cables

Do not forget to provide the computer with power and a network connection.



Summa nv
Rochesterlaan 6
8470 Gistel
Belgium

2.3.2 Electrical connection

The electrical cable and wall socket are **NOT SUPPLIED** with the flatbed cutter and must be provided by the end user.

The wall socket and cable plug need to be IEC60309 standard.
The connection to the mains may also be done with an electric wall box.

Power requirements (including Summa's standard vacuum set):

- 3x 208V + N, 60 Hz, max 30A
- Or 3 x 400V + N, 50Hz, max 30A
- Or 3 x 230V, 50Hz, max 30A

Power cable:

- Length: Distance between machine and socket + 2m
- 3 or 4 core + ground (according to grid voltage)
- Overall diameter: between 9 mm (0.36") and 17 mm (0.67")
- **Europe:** The section of each core must be at least 4 mm² (3 X 400V + N and 3 X 230V). If the cable is longer than 25m, the section must be at least 6 mm².

North America: The diameter of each core must be at least AWG 10 with MTW rating for the North American market (3 x 208V + N). External overcurrent protection 208Y/120V, 40A max, 10 kA interrupting capacity.



Figure 4: IEC60309 Plug and Socket – reference picture



ATTENTION: Be sure to check the regional electrical requirement for the type of wall socket and plug, and fuse for the wall socket or electrical wall box.

2.3.3 Pneumatic connection

The pneumatic tube and connector are **NOT SUPPLIED** with the flatbed cutter and must be provided by the end user.

Pneumatic tube:

- Ø10mm
- Length: Distance between machine and compressor + 2m

Connector:

- 1: Ø10mm connection for pneumatic tube
- 2: Thread for connection to compressor or quick coupler

Compressor:

- Without pneumatic tools/options:
 - 7 bar (100 PSI) @ 20 l/min (0.72 cfm)
- With HF router option:
 - Particle Class 3
 - Water Class 4
 - Oil Class 3
- With POT:
 - 7 bar (100 PSI) @ 350 l/min (12.4cfm)
 - Class 4 ISO 8573-1 or additional air cleaner/dryer



Figure 5: Pneumatic Connector – Reference Picture

2.4 Requirements for router option

The router is an option that must be installed by a technician. It involves both mechanical and electrical changes to the table.

Please check the router installation instructions for the minimum requirements.

2.4.1 Vacuum cleaner for all router options

Currently, Summa offers 2 types of vacuum cleaners:

- Metabo (small)
- Hercules (big)



ATTENTION: The above-mentioned vacuum cleaners can only be used in Europe.

Type	3x400V + N, 50Hz	3 x 230V, 50Hz	3x 208V + N, 60 Hz	3x 208V, 50-60 Hz
Metabo	OK	OK	Cannot be used	Cannot be used
Hercules	OK	Extra socket ⁽¹⁾	Cannot be used	Cannot be used
3rd party	Max. 3000W	Max. 2400W or	Max 1500W ⁽²⁾ or	Max 1500W ⁽²⁾ or
		Max. 3000W with: Extra socket ⁽¹⁾	Max 2000W ⁽²⁾ with: Extra socket ⁽¹⁾	Max 2000W ⁽²⁾ with: Extra socket ⁽¹⁾

⁽¹⁾ 'Extra socket' means that a secondary wall socket (single phase) needs to be provided for the vacuum cleaner.

⁽²⁾ Specifications given for a 110V vacuum cleaner.

Specifications for third party vacuum cleaners:

- Air Output (at fan): Min 3.000l/min (106 cfm)
- Vacuum: Min 230 hPa (mbar) (92 Inch of water)
- Hose diameter is 35 – 38mm (exact specifications of connection can be found on the internet under 'screw cuff a72-84V')

2.5 Installation tools

Please consult the corresponding extensive F-Series installation manual for a complete list of the tools that are needed for the installation.

2.6 System requirements

Dedicated PC or laptop with hardware components that are up to date with the today standards.

- **OS:** Windows 10
- **Screen:** Full HD
- **USB:** At least 1 free USB connection and an optional one (if remote has been ordered).



ATTENTION: Other Window **versions** are also available: the N edition for Europe and the KN edition for South Korea. If one of these editions is installed, the media pack has to be installed as well, to avoid camera problems. To install the media pack, go to: <https://support.microsoft.com/en-us/help/3145500/media-feature-pack-list-for-windows-n-editions>.



ATTENTION: It is highly recommended to use a dedicated computer to connect to the table. If other programs and services not related to driving the table are running, they can take up too many resources so that the minimum system requirements will no longer suffice.



F SERIES™

3 PAGES FOR COMPLETION AND SIGNATURE

Complete the following pages, sign off the certification page; scan them (or take a picture) and mail them to installations@summa.com.

3.1 Preparational checklist

Machine to be installed: _____

- The truck can be unloaded, and the crates can be transported inside.
- A forklift or pallet truck(s) with the correct lifting capacity will be available.
- Three people are available for setting up the chassis of the machine (later two people).
- There is a clear path to the installation area (so no steps, stairs, radiators,...).
- The installation area is free. It is recommended to mark this area on the floor.
- The installation floor meets the requirements.

All necessary connections and parts to connect them (choose one of the below):

- are available and ready.
- will be prepared by someone who knows the local power requirements and will be available during the installation.

3-phase power supply and type: _____

Compressor specifications: _____

- A dedicated PC is or will be ready for use and installation of the necessary programs to operate the cutter.
- The future operator of the cutter is available during the entire training.
- The environment complies with the requirements for operating the machine.

3.2 Extra Info

Software used:

- Operating system: _____
- Designing: _____
- RIP: _____

Extra information or requests:



3.3 Certification

I hereby declare that all preparatory work on site has been completed and that the necessary parts/tools and people will be available during installation and training.

Company name _____

Name _____

Date _____

Signature _____

4 SAFETY PRECAUTIONS



These installation instructions are for use by qualified service personnel only. Risk of electric shock. Hazardous voltage present for up to 5 minutes after disconnection of power supply. To reduce the risk of electric shock do not perform any servicing other than that contained in the operating instructions unless you are qualified to do so.



Contains Class II laser. Do not stare into the beam. Complies with CFR Title 21, Chapter I, Subchapter J, Sections 1010.2, 1010.3, 1040.10 and 1040.11 in effect at date of manufacture. Caution: use of any controls, adjustments, or procedures other than those specified herein may result in hazardous radiation exposure.



Sharp edges. Touching the tools with bare hands may cause injury. Do not touch.



Moving parts. Keep body parts out of the motion path. This equipment is not suitable for use in locations where children are likely to be present. This equipment is not intended for use by children. Avoid touching the moving parts and entering the cutting area with the hands, clothing, jewellery, or hair. Unplug this appliance if it will not be used for an extended period of time.



Hot surface. Do not touch these parts.



Hearing protection should be worn in case of prolonged exposure to the noise of the vacuum pumps. Eye and/or hearing protection must be worn when using certain power tools.