



HP Stitch S1000 126-in Printer

Site Preparation Guide

© 2019–2021 HP Development Company, L.P.

Edition 3

Legal notices

The information contained herein is subject to change without notice.

The only warranties for HP products and services are set forth in the express warranty statement accompanying such products and services. Nothing herein should be construed as constituting an additional warranty. HP shall not be liable for technical or editorial errors or omissions contained herein.

Table of contents

1 Introduction	1
System configuration	1
Documentation	1
Site preparation overview	1
Customer responsibility	2
2 Site preparation	5
Planning for printer installation	5
Installation time schedule	5
System operation requirements	6
Air supply requirements (pneumatic spindle)	12
Room and spacial requirements	13
Designing the print production area	18
Computer and networking requirements	20
3 Shipment arrival preparation	24
Unloading area	24
Route from unloading site to installation site	24
Shipment items	25
Tools and manpower required for installation	25
Moving equipment	25
Waste disposal	28
4 Installation checklist	29

1 Introduction

System configuration

Your printer is supplied almost fully assembled and ready for the simple installation procedures described in detail in the installation guide. It comes complete with printheads and a printhead cleaner roll.

Documentation

The following manuals are provided with your printer, and can also be downloaded from <http://www.hp.com/go/StitchS1000126in/manuals/>:

- Introductory information
- Limited warranty
- Legal information
- Site preparation guide (this document)
- Installation guide
- Installation checklist
- User's guide

Site preparation overview

This guide should assist in the following planning considerations:

- Modifications to the installation area
- Site accessibility
- Emergency exits
- Planning the print production area
- Mechanical, electrical and environmental specifications
- Computer and network connectivity
- Contracting a specialist mover with a forklift and/or suitable moving equipment; needed only if the site does not comply with the specifications to download the printer with the provided ramps
- Contracting an electrician

All information in this guide is provided on the assumption that installation planners and personnel are familiar with:

- Architectural and planning requirements
- Applicable laws, regulations and standards



NOTE: It is important to read the information provided in this guide thoroughly and ensure complete compliance with all installation and operation prerequisites, safety procedures, warnings, cautions, and local regulations.

Customer responsibility

Planning the site and printer environment

You are responsible for all preparations of the physical site, and you must complete the following tasks:

- Prepare the site for unloading. See [Unloading area on page 24](#).
- Make sure the route from the unloading site to the installation site meets specifications. See [Route from unloading site to installation site on page 24](#).
- Make sure you have the necessary equipment to handle the printer, as well as a specialist mover who is familiar with your site and the information provided in this guide. See [Moving equipment on page 25](#).
- Meet the requirements for second floor installations (if necessary). See [Above ground floor installation on page 27](#).
- Configure the building's electrical system used to power the printer to meet the printer's requirements and the Electrical Code requirements of the local jurisdiction of the country where the equipment is installed. A qualified electrician is required to power up the printer on the day of installation. See [Electrical configuration on page 6](#).
- Provide an adequate air supply for the pneumatic spindles. See [Air supply requirements \(pneumatic spindle\) on page 12](#).
- Meet temperature and humidity requirements and ensure proper ventilation for the printer. See [Ventilation specifications on page 13](#) and [Environmental specifications on page 13](#).
- Provide active exhaust installation, especially if the printer is intended for intensive printing with the ink collector. Meet the requirements specified for the printer's aerosol-extractor. See [Local exhaust specifications: on page 14](#).
- Supply all necessary emergency equipment. See [Safety installations on page 18](#).

RIP installation

If you have bought HP RIP software for your printer:

- You must ensure that a computer is available on which to install the RIP.
- For full functionality, you are recommended to ensure that the computer is connected to the Internet.
- You must ensure that the HP RIP software has arrived by the agreed date of printer installation.

If you have bought non-HP RIP software for your printer:

 **NOTE:** This guide does not provide information about your RIP solution.

- You must install the RIP on a suitable computer and ensure that it is fully functional by the agreed date of printer installation.
- For full functionality, you are recommended to ensure that the computer is connected to the Internet.
- You must ensure that a RIP specialist and a network specialist are present on the agreed date of printer installation.

Networking

You are responsible for all networking requirements, and you must complete the following tasks:

 **NOTE:** In order to perform remote support, the printer must have access to the internet using the LAN connection.

- Have an adequate network ready for the day of installation. See [Computer and networking requirements on page 20](#).
- Provide a CAT-6 LAN cable to connect the printer to your LAN on the day of installation.

Printing supplies for testing and training

You are responsible for providing the following printing supplies:

- Four ink cartridges, for the four colors (no cartridges are supplied with the printer)

 **NOTE:** In addition, you are recommended to have a second set of four ink cartridges, four printheads, and one HP Stitch Printhead Cleaning Kit, in case any replacements are needed.

- Compressed air supply for the pneumatic spindle. See [Air pressure supply on page 12](#).
- Some rolls of substrate for printing; preferably the substrate type that you plan to use most in future

Return the site preparation checklist

The checklist must be completed and returned to your reseller or service representative a minimum of two weeks before the day of installation.

 **NOTE:** Any delays during installation that are caused by an unprepared site will be charged to the customer. Take care that your site is properly prepared to ensure a smooth and easy installation.

Recycle the disposable ink bag and HP Stitch Printhead Cleaning Kit

These items require disposal according to local regulations. For further information, please refer to the MSDS document about your printer's ink, available from <http://www.hp.com/go/msds>.

Recycle the printheads

The printheads require disposal according to local regulations. For further information, please refer to the MSDS document about your printer's ink, available from <http://www.hp.com/go/msds>. Within some countries covered by the 'HP Planet Partners Returns', HP is offering a recycling program. For full details of this program, see <http://www.hp.com/recycle/>.

Dispose of liquid waste

Dispose of liquid waste in compliance with all applicable federal, state, and local regulations.

Dispose of the HP filtering device

Dispose of the active carbon filter in compliance with all applicable federal, state, and local regulations.

2 Site preparation

Planning for printer installation

This chapter covers the main topics related to efficient planning and preparation of the site. Take into consideration any structural modifications required and the time required for submission and approval of plans to the relevant local authorities. Secure temporary storage for the shipping crate prior to equipment installation may also be necessary.

⚠ CAUTION: All cables connected to the printer should be contained within suitable conduits; these may be overhead or channeled into the floor, as appropriate. Tripping over loose wires or cables can cause personal injury and/or damage to the equipment.

Installation time schedule

The best method to ensure a smooth and trouble-free installation process is proper site preparation. The following time schedule estimate is based on the assumption that all system components have been delivered in proper working order and all site preparation and planning requirements have been met and completed, in accordance with the specifications provided in this guide. The installation process is divided into two phases:

Installation time schedule

	Time to completion
Installation and system configuration	1.5 full working days
Operation and maintenance training	2.5 full working days

Although the optimal time schedule requires approximately 4 working days, it may be necessary to schedule additional time for either phase. Please plan ahead for any special circumstances that may occur during the installation process, and do not plan for production during installation and training.

If the RIP software is bought from HP, the training will cover the normal use of the RIP. The following aspects of RIP usage will be covered:

HP Large Format Onyx Thrive RIP software

- RIP-Queue
- Configure the printer (Quickset, Device output, Media, Page size, Properties)
- Main items of the Job Editor (Printer and media selection, Preview and size, Tiling setup, Color correction, Print)

The Media Manager will not be covered.

HP Large Format Caldera Grand RIP software

- Server Administration (Server, Configure, Connection)
- GrandRIP+ (Main, Tool, Settings)
- Spooler
- Image Work Directory (Image positioning and scale setting on the page, and so on)

HP Ergosoft RIP S1000 Color Edition software

- ErgoSoft RIP JobComposer
- ErgoSoft RIPServers
- Drivers and print clients (easy-to-use queue management, production control, and device maintenance)

Profile creation will not be covered.

System operation requirements

Electrical configuration



NOTE: An electrician is required for the setup and configuration of the building electrical system used to power the printer and also for printer installation. Make sure that your electrician is appropriately certified according to local regulations and supplied with all the information regarding the electrical configuration.

The HP Internal Print Server can be powered with a single-phase line that can be used with an Uninterruptible Power Supply (UPS). The UPS must be rated to meet the power requirements of the printer, and should be in accordance with the wiring standards of the country of installation.

The printer requires the following electrical components to be supplied and installed by the customer, according to the Electrical Code requirements of the local jurisdiction of the country of installation.

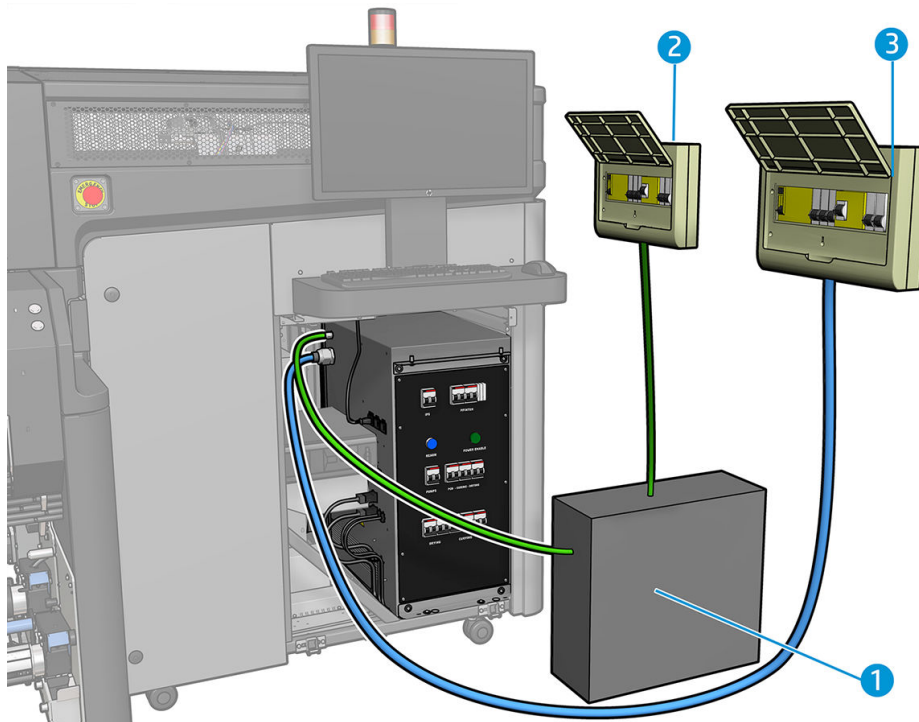

1. Uninterruptible Power Supply (UPS) for single-phase control line (optional)

NOTE: The HP Internal Print Server power can be obtained by making a connection inside the electrical cabinet.

2. Power Distribution Unit (PDU) including single-phase branch circuit breaker (optional)
3. Power Distribution Unit (PDU) including three-phase branch circuit breaker depending on the power configuration

NOTE: Remember that you are required to follow the local laws, regulations, and standards that apply to the electrical installation of your printer.

NOTE: The printer is not supplied with any power cable.

Power distribution unit (PDU)

The PDU must be rated to meet the power requirements of the printer, and should be in accordance with the Electrical Code requirements of the local jurisdiction of the country where the equipment is installed.

Power specifications

Configuration 1: 380–415 V line-to-line three-phase configuration

Three-phase specifications

Number of power wires	5 (L1/L2/L3/N/PE)
Input voltage (line to line)	380–415 V
Input frequency	50/60 Hz

Three-phase specifications (continued)

Power consumption (typical)	9 kW (6 kW when not using a contact heater)
Maximum load current (per phase)	23 A

Branch circuit breaker specifications

Three-phase	4 poles, 25/30 A
-------------	------------------

AC three-phase power cable specifications

Configuration	5 wires, L1/L2/L3/N/PE
Wire	Strained Cu minimum, 6 mm ² or 10 AWG
Terminals	Lines, ferrule terminals, PE, M8 ring terminal
External diameter range	22.0–33.0 mm

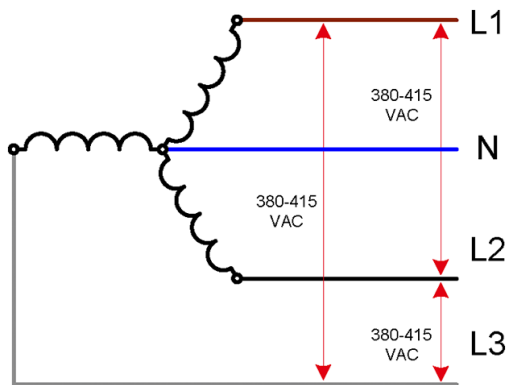

Configuration 2: 200–240 V line-to-line three-phase configuration

Three-phase specifications

Number of power wires	4 (L1/L2/L3/PE)
Input voltage (line to line)	200–240V
Input frequency	50/60 Hz
Power consumption (typical)	9 kW (6 kW when not using a contact heater)
Maximum load current (per phase)	32 A

Branch circuit breaker specifications

Three-phase	3 poles, 32/40 A
-------------	------------------

AC three-phase power cable specifications

Configuration	4 wires, L1/L2/L3/PE
Wire	Strained Cu minimum, 6 mm ² or 8 AWG
Terminals	Lines, ferrule terminals, PE, M8 ring terminal
External diameter range	22.0–33.0 mm

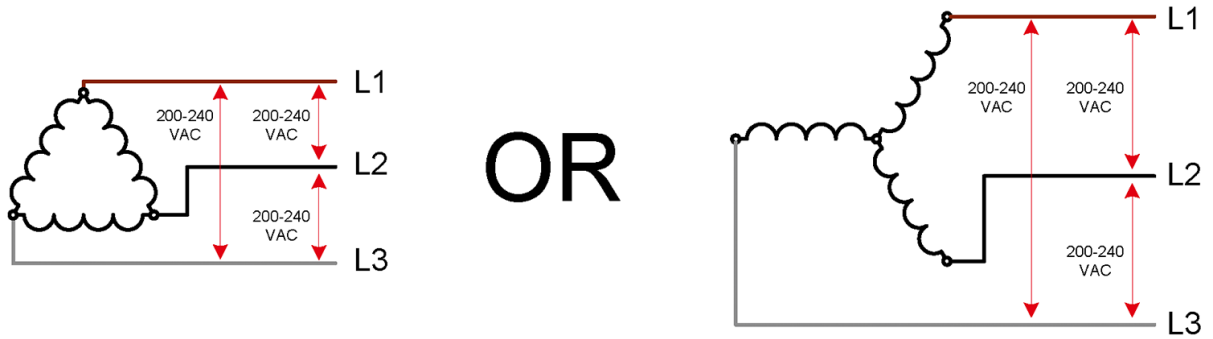

Configuration 3: 380–415 V line-to-line three-phase configuration with single-phase control

Specifications

	Three-phase line	Single-phase control
Number of power wires	5 (L1/L2/L3/N/PE)	3 (L/N/PE)
Input voltage (line to line)	380–415 V	100–240 V
Input frequency	50/60 Hz	50/60 Hz
Power consumption (typical)	9 kW (6 kW when not using a contact heater)	0.5 kW
Maximum load current (per phase)	23 A	10 A

Branch circuit breaker specifications

Three-phase	4 poles, 25/30 A
Two-phase control	2 poles, 15/16/20 A

AC Power cable specifications

	Three-phase line	Single-phase line
Configuration	5 wires, L1/L2/L3/N/PE	3 wires, L/N/PE
Wire	Strained Cu minimum, 6 mm ² or 10 AWG	Strained Cu minimum, 1.5 mm ² or 16 AWG
Terminals	Lines, ferrule terminals, PE, M8 ring terminal	Lines, ferrule terminals, PE, M4 ring terminal
External diameter range	22.0–33.0 mm	5.0–11.0 mm

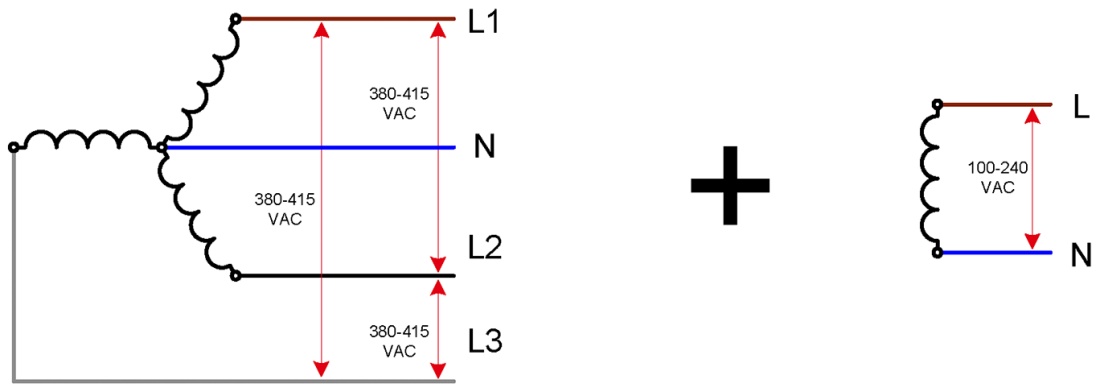

Configuration 4: 200–240 V line-to-line three-phase configuration with single-phase control

Specifications

	Three-phase line	Single-phase control
Number of power wires	4 (L1/L2/L3/PE)	3 (L/N/PE)
Input voltage (line to line)	200–240 V	100–240 V
Input frequency	50/60 Hz	50/60 Hz
Power consumption (typical)	9 kW (6 kW when not using a contact heater)	0.5 kW
Maximum load current (per phase)	32 A	10 A

Branch circuit breaker specifications

Three-phase	3 poles, 32/40 A
Two-phase control	2 poles, 15/16/20 A

AC Power cable specifications

	Three-phase line	Single-phase line
Configuration	4 wires, L1/L2/L3/PE	3 wires, L/N/PE
Wire	Strained Cu minimum, 6 mm ² or 8 AWG	Strained Cu minimum, 2.5 mm ² or 16 AWG
Terminals	Lines, ferrule terminals, PE, M8 ring terminal	Lines, ferrule terminals, PE, M4 ring terminal
External diameter range	22.0–33.0 mm	5.0–11.0 mm

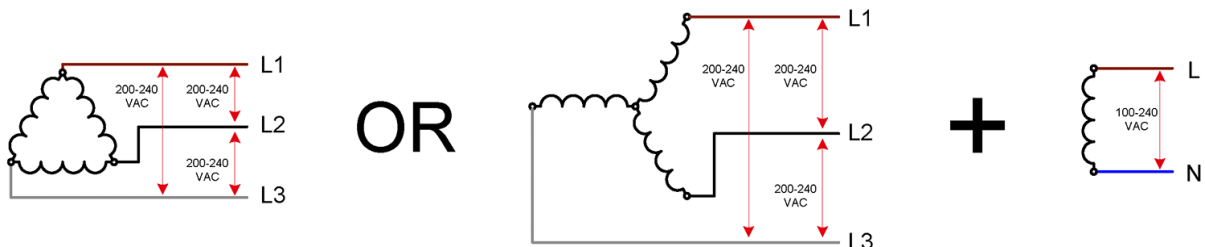



Circuit breakers (required)

The circuit breakers must meet the requirements of the printer and should be in accordance with the Electrical Code requirements of the local jurisdiction of the country where the equipment is installed.

The printer requires one or two branch circuit breakers, depending on the installation.

 **NOTE:** The printer has built-in Residual-Current Circuit Breakers (RCCB), also known as Ground Fault Circuit Interrupters (GFCI), with 30 mA sensitivity. If local laws require an external RCCB or GFCI for earth fault protection, install a device with sensitivity of 100 mA or higher, with appropriate rated current for the supply configuration, and ensure that other protective devices for earth fault protection upstream from the one supplying the printer are always greater than the one selected for the printer.

 **WARNING!** The rated short-circuit breaking capacity of the circuit breakers in the printer is 6 kA. This shall be coordinated with the branch circuit breaker in PDU (Power Distribution Unit) if so required by the Electrical Code of the local jurisdiction.

 **WARNING!** Ensure that the printer's built-in Residual-Current Circuit Breakers (RCCB) or Ground Fault Circuit Interrupters (GFCI) operate in the case of a current leakage fault to the product chassis, even when an isolation device (such as an isolating transformer) will be used to supply power to the printer.

Power cables

No power cable is provided with the printer. The cables that you use must meet the minimum specifications for the chosen configuration explained for each configuration.

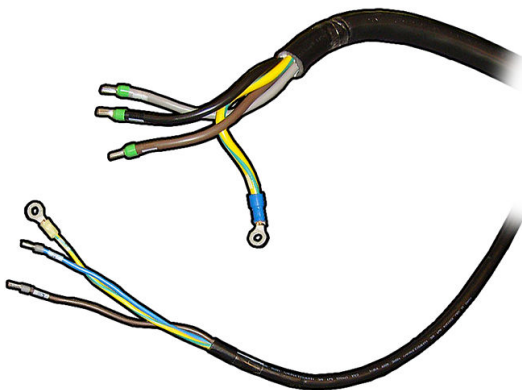

PE connections for mains power should be made through an M8 stub.

The power cable for PC power can be routed from above the right of the top cover; it can be routed from the ceiling.

Powerline disturbances

Reliable operation of your printer depends on the availability of relatively noise-free AC power.

- In order to ensure optimum performance and reliability, your printer should be protected from variations in line voltage, which are common to production printing environments. Lighting, line faults, or the power switching commonly found in machinery in factory environments can generate line transients that far

exceed the peak value of the applied voltage. If not reduced, these micro-second pulses can disrupt system operation.

- If the power line supplying the installation site is a public low voltage line shared with other users, the power line impedance Z_{max} must be less than 50 m Ω , to comply with European standard EN/IEC 61000-3-11. If other users on the same power line report any flickering of incandescent light bulbs, contact your electricity supplier to verify that the power network has an impedance lower than the one specified above.
- It is recommended to include overvoltage (OVP) and transient protection on the power supply to the printer.
- All electrical noise generating equipment, like fans, fluorescent lighting, and air-conditioning systems, should be kept separate from the power source used for your printer.

Grounding

The printer must be connected to a good quality, dedicated ground line in order to avoid electrical risk. Please note your obligation to comply with the National Electrotechnical Code (NEC) in the county of installation.

The following grounding tasks must be fulfilled to meet the site preparation requirements:

- Grounding wires should be insulated and at least equal in size to the phase conductors.
- Ground impedance must be less than 0.5 Ω .
- The installation of a single point and dedicated ground.
- Power stabilizer equipment that is supplied by three uninterrupted phase wires and one uninterrupted copper ground wire from the main building service panel. These should run in the same conduit and should be at least equal in size to the phase wires.

Air supply requirements (pneumatic spindle)

Air pressure supply

The pneumatic spindle requires an air compressor or pressurized air line that must be provided by the customer.

 **TIP:** HP recommends that you use an air compressor with a pressure gauge that measures in bars.

Air pressure	5.5 bar (80 psi) (required)
Minimum airflow	30 liters/minute (1.06 cubic feet/minute)
Lubricator (not required)	Not recommended
Air filter (recommended)	Recommendation: 5 μm , auto-drain, 99.97% coalescing efficiency
Regulator (required)	Regulator with pressure gauge

Pneumatic connector

The printer comes with an air gun that you must attach to your air supply. In order to connect your air supply to the air gun, you must meet the following requirements:

- 6.35 mm (0.25 in) female connector, BSP or NPT thread
- PTFE tape to secure the connection and prevent air leaks

⚠ WARNING! Take care when using the air gun. When used for cleaning purposes, make sure to use it according to the local regulations since additional safety provisions may apply

Room and spacial requirements

Environmental specifications

The temperature, humidity, and temperature gradient during operation and during storage must be kept within the standard ranges to ensure the correct operation of the printer. Failure to keep these environmental conditions within the standard ranges may cause image quality problems or damage sensitive electronic components.

	Temperature range	Humidity range	Temperature gradient
Operating for optimal print quality	20 to 25°C (68 to 77°F)	30 to 60% Relative Humidity	10°C/h (50°F/h) or less
Operating for standard printing	15 to 30°C	20 to 70%	10°C/h (50°F/h) or less
Not operating (in transport or storage), ink in tubes	5 to 55°C (41 to 131°F)	90% Relative Humidity at 55°C (131°F)	10°C/h (50°F/h) or less
Not operating (in transport or storage), no ink in tubes	-10 to 55°C (14 to 131°F)	90% Relative Humidity at 55°C (131°F)	10°C/h (50°F/h) or less

Maximum operating altitude: 3000 m (10000 ft)

In addition to controlling the temperature, humidity, and temperature gradient, there are other environmental conditions that must be met during site preparation:

- Do not install the printer where it will be exposed to direct sunlight or a strong light source.
- Do not install the printer in a dusty environment. Remove any accumulated dust before moving the printer into the area.

Ventilation specifications

Ensure that the room in which the system is installed meets local environmental, health, and safety (EHS) guidelines and regulations.

Adequate ventilation needs to be provided to ensure that potential airborne exposure is adequately controlled. Consult the Safety Data Sheets available at <http://www.hp.com/go/msds> to identify chemical ingredients of your ink consumables. Airborne materials can be readily identified and quantified by using established indoor air-quality testing protocols. HP performs these assessments during the development phase for all products. If you will need to work with the contact heater activated, HP provides you with the local exhaust or filtration options (see below) to help you to be compliant with your local EHS guidelines and regulations.

General ventilation requirements

A minimum of 5 ACH (air changes per hour) of fresh air ventilation and a minimum room volume of 100 m³ is required. These specifications are valid for the following conditions: one HP printer using a black area-fill plot at around 130 m²/h, 4 passes, and 100% of ink, assuming 8 hours of printing time a day.

Customers should recognize that actual levels in their facilities are dependent on workspace variables such as room size, ventilation performance, and duration of equipment use. Ventilation rate should be recalculated if customer installation parameters are different.

Ventilation rates may vary depending on other factors as well. Rates should be recalculated if, for example, there is equipment not provided by HP ("Third-Party Equipment") located in the room. In this case, please consider that in addition to the workspace benefit provided by general room ventilation when using the HP printer, Third-Party Equipment (for example the calendaring system, heat fixation system, and so on) may need the use of localized ventilation in order to provide an acceptable working environment. Please verify with the supplier or manufacturer the correct ventilation approach when using Third-Party Equipment. Notwithstanding anything to the contrary in this ventilation section or elsewhere in this guide, HP shall not be responsible for any loss or damage, whether direct or indirect, to the customer, its employees, or any other third parties arising from the customer's use of Third-Party Equipment.

Local exhaust (Option 1)

When the contact heater is activated, the system can use localized ventilation in order to provide an acceptable working environment. This installation of a localized exhaust for a printer enables the capture of airborne contaminants and heat near the source of their generation, and subsequently allows their efficient removal from the building through contained, and relatively low-volume air flow.

A workspace health and safety professional can provide guidance on the design, installation, and use of this auxiliary ventilation equipment.

Local exhaust specifications:

Ensure that the following parameters are met in order to ensure good local exhaust performance:

- Airflow: 750 m³/h ±5%
- Pressure: -600 Pa ±5%
- Tube diameter: 120 mm
- Maximum tube length that will not affect pressure and airflow in the system: 5 meters

These parameters need to be measured in the printer exhaust, with the external tubes installed, while printing.

 **NOTE:** If the tube is longer than 5 m, the site should adapt its configuration to ensure these values are met.

These parameters should be measured at the local-exhaust printer connection, while the printer is in a printing state. HP recommends not using ABS, PC, Steel, or EG Steel materials for the local exhaust installation. PVC, SS, PP, or aluminum are better options.

 **NOTE:** The nozzle exit exhaust cannot support more than 5 kg. Pipes with a weight of 5 kg or more should be anchored to the building structure.

HP filtering device (Option 2)

When the contact heater is activated, as an alternative to the local exhaust option you can install the HP Stitch S1000 Carbon Filter (324P9A) filtering device in order to provide an acceptable working environment. The

filtration solution enables the adsorption of airborne contaminants near their source of generation, until the end of its life. Filter replacement depends on the usage model (ink consumption/day). The printer will alert you when the filter needs to be replaced. This is under the customer's responsibility.

How to choose the correct extraction pump

If the local exhaust does not meet the conditions described in the previous section (Exhaust specifications), check the product data sheet and look for the characteristic curve of the pump. With the extractor pump connected to the printer (connecting tube must be of diameter 114 mm, and length between 1 m and 3 m), the characteristic curve of the pump must be within the "OK" box as shown in the following graph.

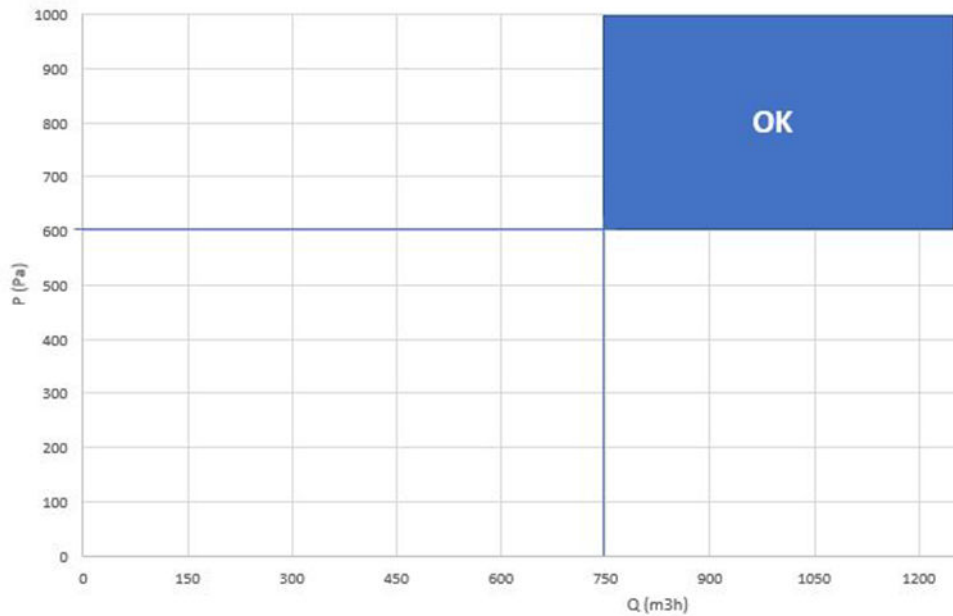

If the characteristic curve of the pump is higher than the point 750 m³/h; -600 Pa, then the pump is within the required specifications and it will work as expected, otherwise you should choose another device.

The following graphs show a few examples of pumps within required specifications:

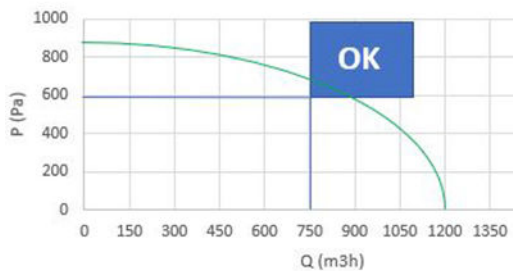

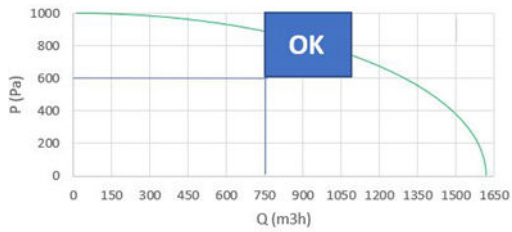
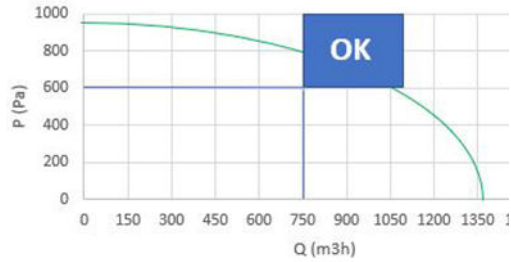

And some examples of pumps that will not work:

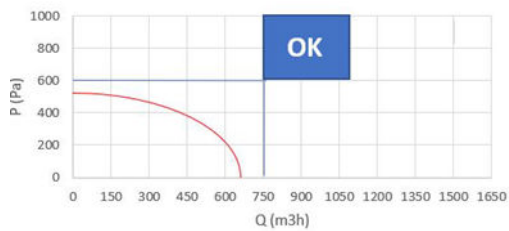
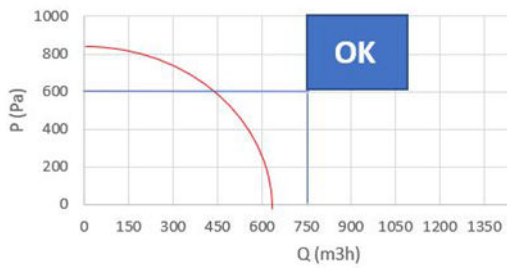
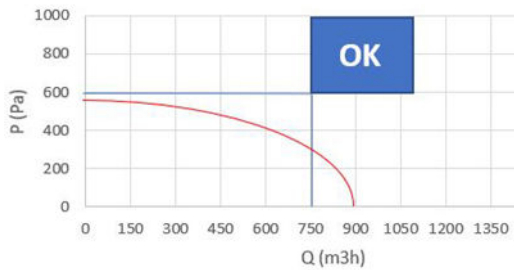

For more details contact the pump vendor.

Air conditioning

In addition to fresh air ventilation, to avoid health hazards, also consider maintaining workplace ambient levels by providing the climatic operating conditions specified in this document (see [Environmental specifications](#))

[on page 13](#)) to avoid operator discomfort and equipment malfunction. Air conditioning in the work area should take into account that the equipment produces heat. Typically, the printer's power dissipation is 6.0 kW (20.5 kBTU/h).

Air conditioning should meet local environmental, health, and safety (EHS) guidelines and regulations.

 **NOTE:** The air conditioning units should not blow air onto the equipment.

Load bearing

The load-bearing characteristics of the floor in the print production area must be sufficient to withstand the weight of your printer. To calculate the load bearing characteristics of the print production floor, you must consult a structural engineer.

Printer weight with crate	1945 kg (4288 lb)
Printer weight without substrate	1205 kg (2657 lb)
Load on each foot	600 kg (1323 lb)

Your printer has four wheels used to move the printer and three feet that must be lowered to touch the ground and support the printer. The following diagram shows where the feet and wheels touch the ground, in case you need extra reinforcements.

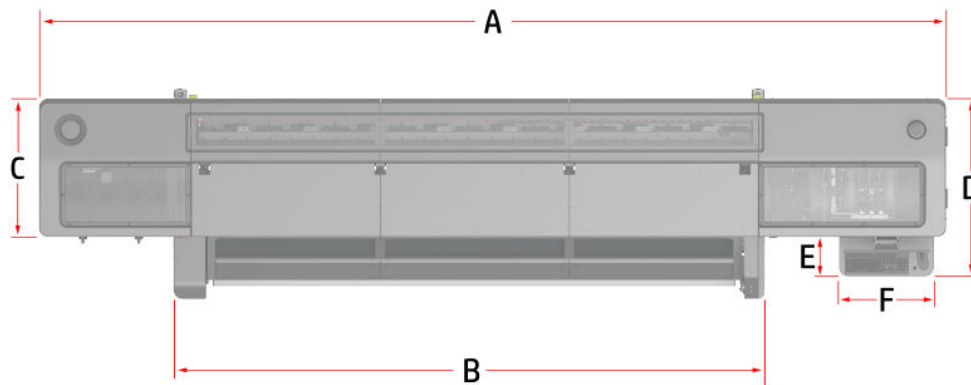

In the table below, the letter in the left column corresponds to the diagram above.

A	5.7 m (224.4 in)
B	3.73 m (146.8 in)
C	1.12 m (44.1 in)
D	1.37 m (53.9 in)
E	0.25 m (9.8 in)
F	0.60 m (23.6 in)

Floor surface

The floor surface should have the following characteristics:

- Horizontal surface
- Solid, smooth, and level
- No holes or indentations
- Static-free surface (no carpet)
- Easy to clean
- Durable
- Free from strong vibrations
- Concrete

Lighting

Whenever your printer is in operation, the print production area should be well lit to provide the operator with optimal conditions for checking the color and alignment during print production. If there is not enough natural light, artificial lighting will be required.

Designing the print production area

Safety installations

Fire fighting equipment

You must provide two fire extinguishers for the site. Make sure the extinguishers are placed where they are easily accessible in case of fire.

- A fire extinguisher certified for electrical fires must be in the print production area.
- A fire extinguisher must be placed in the substrate storage area, due to the large amount of solid combustibles (substrates).

Emergency exits and first aid stations should also be considered.

Optimal room layout

Your printer requires enough space to perform the following tasks:

- Print
- Use the HP Internal Print Server
- Replace a substrate roll
- Service the printer or replace printer components
- Ensure the printer is well ventilated

Your printer has the following dimensions:

Weight	1205 kg (2657 lb)
Width	5.74 m (226 in)
Depth	1.38 m (54.3 in)
Height	1.67 m (65.7 in)

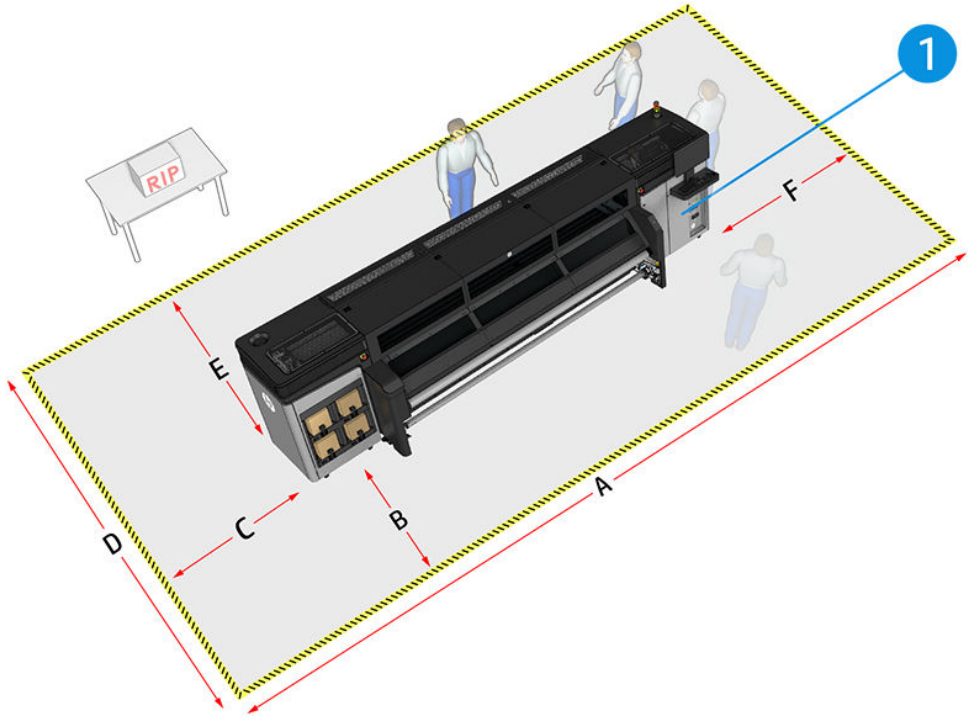

1. Electrical connection.

In the table below, the letter in the left column corresponds to the room layout illustration above.

Measurement	
A	8.725 m (28 ft 7.5 in)
B	1.5 m (4 ft 11 in)
C	1.5 m (4 ft 11 in)
D	4.27 m (14 ft)
E	1.5 m (4 ft 11 in)
F	1.5 m (4 ft 11 in)

The ceiling of the room should be at a minimum height of 2.5 m (8 ft 3 in) above the floor.

⚠ WARNING! The zone surrounding the printer should be considered a restricted access area and signaled accordingly. Only trained personnel should be operating within this area.

Storage area for materials

When planning a storage area for materials used with the printer, thought should not only be given to safety and convenience, but also to the fact that if inks and substrates are not stored in the appropriate temperature and humidity conditions, print results may be adversely affected.

The storage area should be of sufficient size to accommodate adequate stocks of substrate rolls and inks. The storage area should be located near the print production area to minimize the lifting and maneuvering of heavy materials.

The storage area should have a covered roof. It should be dry, well ventilated and able to provide protection from direct light. It is important that temperature and humidity are maintained within values specified for each substrate type.

 **NOTE:** Allow enough (environmentally controlled) space to store the printheads. This is indicated by the directional arrows on the printhead boxes.

Storage conditions for substrate rolls

Keep substrate rolls in their sealed wrapping material while they are placed in storage.

Store substrate rolls vertically to avoid the migration of plasticizers in some materials.

Move substrates from the storage area to the print production area at least 24 hours before use, so that they can reach the required moistness and operating temperature.

 **NOTE:** HP substrate rolls have a 12 month warranty when the substrate rolls are stored under optimal conditions. The warranty term varies depending upon the material and the manufacturer.

Computer and networking requirements

Requirements

- Print Care network functionality requires an outbound connection to all the following addresses *without* a proxy. This means that an open Internet connection allowing traffic on ports 80, 443, and 21 is needed.

URL	HTTPS 443	HTTPS 80	FTP 21	Used for
http://www.hp.com/		X	X	Print Care / Production Analyzer Content and Data Connectivity
https://spcastweb01p.saas.hp.com/	X	X		
http://spcw01.saas.hp.com/		X		
https://hpprotagonist.com/		X		
https://hplargeformatremote.com/		X		Solutions communication
https://seals.corp.hpcloud.net/		X		
*.heleni.me		X		
*.hp.com		X		
*.printos.com		X		

 **NOTE:** If necessary, please instruct the customer IT to create routing rules that route around the proxy for these addresses.

- ActiveX must be installed on the computer. Install ActiveX if requested to do so.

The anti-virus application must be configured not to block ActiveX controls.

ActiveX must be enabled in Internet Explorer:

Select **Tools > Internet Options > Security tab**. Then select the Internet zone and click **Custom Level**.

Under ActiveX controls and plug-ins:

- Allow previously unused ActiveX controls to run without prompt.
 - Enable automatic prompting for ActiveX controls.
- A minimum upload speed of 256 bps is required.

HP-provided components

- HP Internal Print Server
 - PC and power cord. PC LAN card connections: 2 Ethernet ports, one for the e-box LAN cable to connect the printer to the PC, and the other to connect to the network
 - Monitor and power cord
 - Keyboard
 - Mouse
 - Windows 10
 - HP Internal Print Server software
 - HP Scitex Print Care software
- 1 Gb Ethernet cables

Customer-provided components

- Ethernet LAN (minimum 100 Mb/s, optimum 1 Gb/s) connection
- RIP station and software
- CAT-6 LAN cable long enough to connect the printer to the network

RIP requirements

There are three RIPs offered by HP that may be used with the printer:

- HP Large Format Onyx Thrive RIP, from version 18.5 onwards: product number D9Z41B
- HP Large Format Caldera Grand RIP, from version 12 onwards: product number L5E74C
- HP Ergosoft RIP S1000 Color Edition: product number 7JC63A

The software and hardware requirements of these RIPs are as follows.

HP Large Format Onyx Thrive RIP

- Main workstation requirements:
 - Windows 7 Professional, Enterprise, or Ultimate; Windows 8.1 Professional or Enterprise; or Windows 10 Professional or Enterprise

 **NOTE:** 32-bit operating systems have a hardware limit of 4 GB of RAM. HP recommends using 64-bit operating systems for high-volume workflows.

 - Processor: Intel Core i7 or equivalent, minimum 6 available cores, recommended 12 or more cores
 - RAM: 4 GB per RIP and core (for example, one RIP and 6 cores: 24 GB)
 - Hard disk drive
 - Storage: 250 GB
 - Network connectivity: Gigabit Ethernet for TCP/IP printers

 **NOTE:** Firewall and antivirus must be disabled or configured to allow ONYX applications and printer ports (515, 1947, 8889, 9100 and 10000). There may be other ports needed, see device manufacturer's documentation for details.

 - Monitor: 1280 × 1024 pixels, 16-bit color
 - USB port for security key
 - DVD-ROM drive
- Distributed workstation requirements:
 - Windows 7 Professional, Enterprise, or Ultimate; Windows 8.1 Professional or Enterprise; or Windows 10 Professional or Enterprise

 **NOTE:** 32-bit operating systems have a hardware limit of 4 GB of RAM. HP recommends using 64-bit operating systems for high-volume workflows.

 - Processor: Intel Core i7 or equivalent
 - RAM: 4 GB/processing core
 - Hard drive: 250 GB free
 - Network connectivity: Gigabit Ethernet for TCP/IP printers

 **NOTE:** Firewall and antivirus must be disabled or configured to allow ONYX applications and printer ports (515, 1947, 8889, 9100 and 10000). There may be other ports needed, see device manufacturer's documentation for details.

- Thrive Production Manager requirements:
 - Macintosh, Windows PC or Mobile Device with HTML Web browser

For further details of Onyx configuration, see <http://www.onyxgfx.com/system-specifications/>.

HP Large Format Caldera Grand RIP (minimum configuration)

- Linux:

- Operating system: Debian Mate recommended, desktop environment 9.5 (Mate desktop environment 8.6, 8.8, 9.5), which should be downloaded from the Caldera website; or Caldera Debian 2 (APPE3, not APPE4)
- Processor : Intel Core i3, i5, or i7
- RAM : 4 GB or 8 GB (recommended). Minimum 1 GB per core, recommended at least 2 GB per core
- HDD : 250 GB
- Monitor / video card : 1280 × 1024 minimum resolution (NVMe SSD not yet supported)
- Mac:
 - Operating system : OS 10.9+ (check compatibility at <http://www.caldera.com/support/os-compatibilities/>)
 - Hardware : Intel Core i3-, i5-, or i7-based Mac mini, iMac, or Mac Pro. Recent MacBooks can be used for demonstration but are not supported by Caldera in production. PPC-based hardware (G5, G4, ...) not supported.
 - 4 GB or more. Minimum 1 GB per core, recommended at least 2 GB per core.
 - HDD : 250 GB
 - Monitor : 1280 × 1024 minimum resolution

For further details of Caldera configuration, see:

- <https://www.caldera.com/support/minimal-requirements/>
- <http://www.caldera.com/product/grandrip/>

HP Ergosoft RIP S1000 Color Edition

- Operating system: Windows 7 Home (32- or 64-bit); Windows 7 Premium (32- or 64-bit); Windows 8 or 8.1 (32- or 64-bit); or Windows 10 (32- or 64-bit)
- Processors: i7 processor of the last generation recommended, with at least 4.2 GHz or more for each core
- RAM: 8 GB RAM or more recommended with 64-bit operating systems (32-bit systems support only up to 4 GB)

For further details, see <https://www.ergosoft.net/>.

External color profiling

In order to build color profiles for your printer, an external color sensor is needed. Make sure to choose an external spectrophotometer that is compatible with your RIP.

3 Shipment arrival preparation

Unloading area

A suitable unloading area will need to be designated that will be easily accessible to the delivery truck. This will require sufficient space to unload the large crate in which your printer is shipped. When planning this area, consider the following:

- Height and width of entrance to unloading area
- Ramps used to access the unloading area
- Height and size of unloading dock (if applicable)

Route from unloading site to installation site

The route between the unloading area of the printer and the installation site, including any corridors and doorways through which the printer must be transported, is important to proper site preparation and must be planned before the arrival of the printer. This pathway must be clear when the printer arrives. Regarding ground floor room access, transport of the bulky printer components requires:

Doorway, ceiling, and corridor specifications

	Printer	Crate
Minimum doorway width	1.55 m (61.0 in)	1.9 m (74.8 in)
Minimum ceiling height	1.85 m (72.9 in)	2 m (78.8 in)
Minimum corridor width	1.55 m (61 in)	1.9 m (74.8 in)
Minimum corridor width for a 90° turn	3.9 m (154 in)	4.7 m (185 in)

⚠ WARNING! After being removed from the crate, the printer can be moved up or down a ramp of no more than 3% inclination.

💡 TIP: Decide when you will remove the printer from the crate. It is recommended that the shipping crate be unpacked as close as possible to the printer's final destination. Usually, the printer is removed from the crate before moving it to the installation site.

Disassembling the crate requires an electric screwdriver that must be plugged into a power outlet, so make sure that a power outlet is available near the site where you plan to disassemble the crate.

Shipment items

All printer components will arrive in a single crate. The dimensions and weight of the crate and printer are as follows:

Printer and crate physical specifications

	Width	Depth	Height	Weight
Crate (printer inside)	5.86 m (231 in)	1.81 m (71.3 in)	1.91 m (75.2 in)	1945 kg (4288 lb)
Printer	5.72 m (225 in)	1.37 m (53.9 in)	1,67 m/1,53 m (66 in/60.2 in), no beacon	1205 kg (2657 lb)

Tools and manpower required for installation

The installation process requires four capable people in case ramps are used. In case a forklift is used, only two people are needed, usually the installer and the operator. Additionally a certified electrician is required to configure the electrical system.

Check with the installation specialist before delivery to make sure you do not have to supply any tools.

Moving equipment

Ground floor installation

It is highly recommended to lower the printer with the ramps as indicated in the installation guide. In exceptional cases, where ramps cannot be used due to a physical barrier, follow the alternative instructions indicated carefully.

⚠ CAUTION: Unloading and moving the printer and all system components is the customer's responsibility and not HP's. Failure to provide the required moving and lifting apparatus could result in personal injury or damage the printer during installation.

Lower the printer with ramps

The use of specialist moving and lifting equipment is required during the unloading.

You will need to book in advance the services of a contractor/rigger for moving machinery. It is important to confirm that the hired moving specialist and moving equipment will be available when the printer is delivered.

⚠ CAUTION: Unloading and moving the printer and all system components is the responsibility of the customer and not of HP. Failure to provide the required moving and lifting equipment could result in personal injury or damage the printer during installation.

Using a forklift

- Minimum room space to lower: 4.5 m (15 ft) without the crate, or 6.4 m (21 ft) with the crate
- Minimum manpower: Four people
- Flat floor or max 3% inclination

The following equipment is recommended:

- Wide, heavy-duty forklift (required)

	Weight	Minimum fork length	Inner distance between forks
Forklift	6000 kg (13228 lb)	2 m (79 in) for crated printer 1.5 m (59 in) for printer only	1.6 m (63 in)

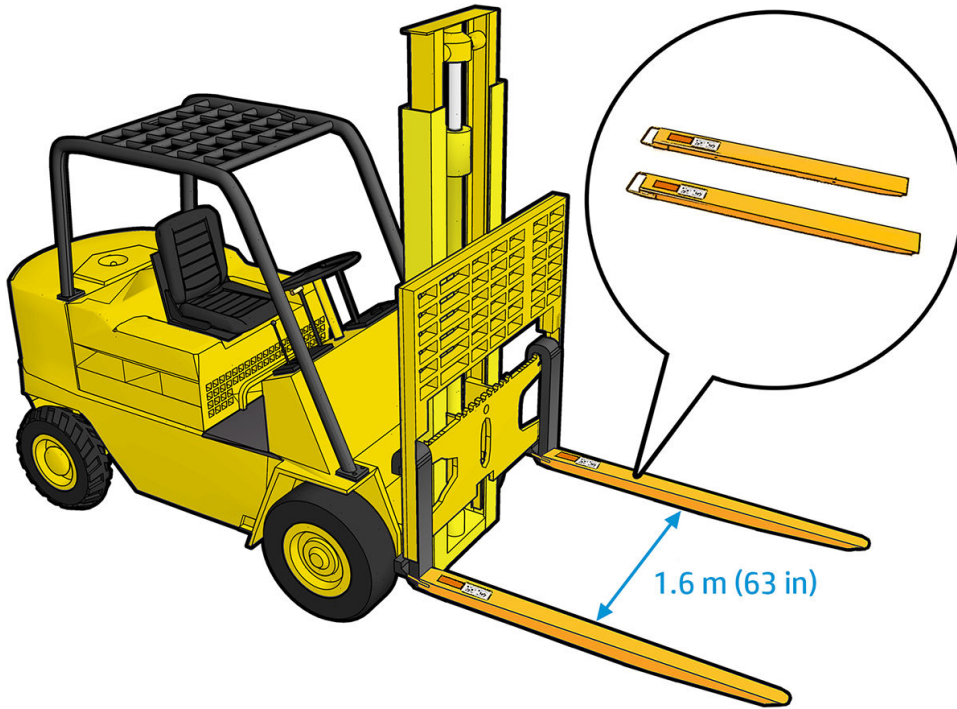

- Two skates to move the crate (optional)

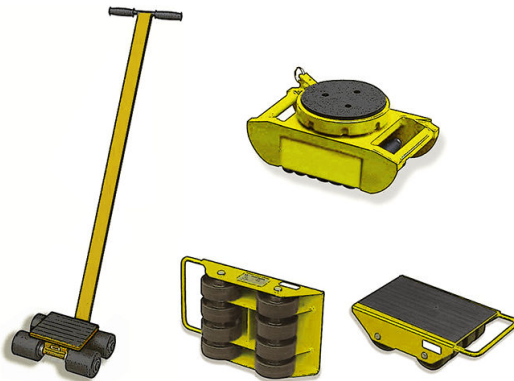

- Electric pallet jack (optional)

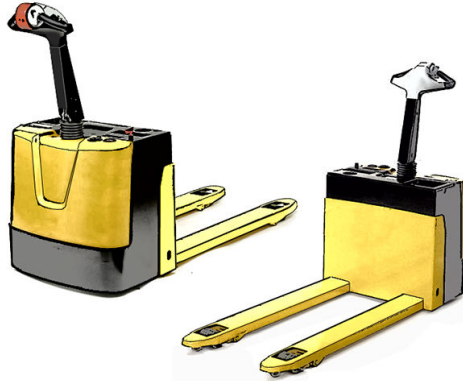

- Manual pallet jack (optional)

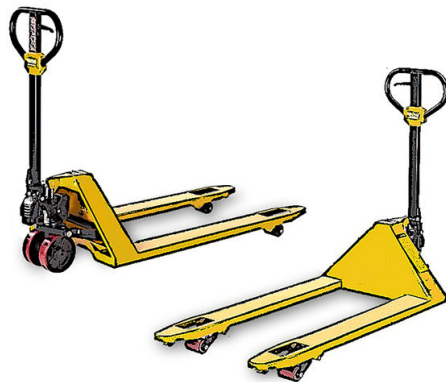

Above ground floor installation

Above ground floor installation requires a crane and special lifting gear in addition to the standard moving equipment. At some installation sites, it may be necessary to remove the crate packaging before lifting the printer with the crane. The following section describes the equipment and configurations needed to lift the printer with a crane.

Crane attachment to lift the printer with a spreader beam

When you lift the printer with a spreader beam, the lifting bars and spreader beam must be long enough so that the lift cables do not touch the printer. The following graphic illustrates how to lift the printer with a spreader beam.

⚠ CAUTION: When lifting the printer with a crane, extra caution should be taken to ensure that the cables do not apply pressure to the scan beam or any other printer component.

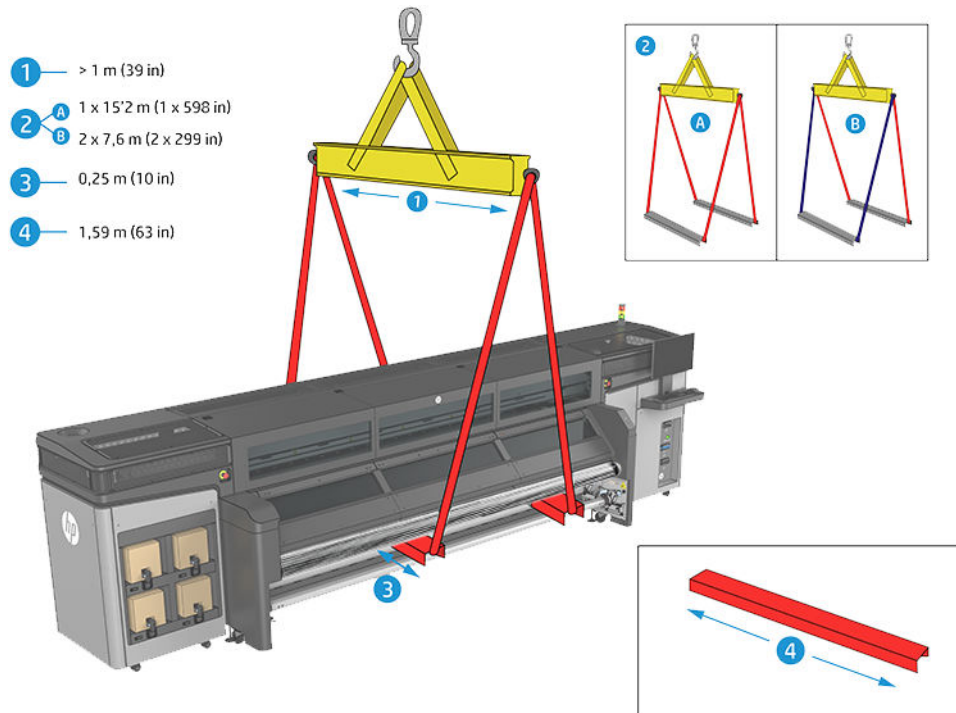

Waste disposal

Printer packaging can be reused for moving the printer at a later date.

The crate and packaging material that comes with the printer can also be disposed of. Most of the waste will be wood materials. Consult with your local authorities to determine the correct manner in which to dispose of waste.

4 Installation checklist

Address information

Company name	Postal code
Street address	Telephone
City	Fax
Country	Email

Contact persons

Name

Telephone

Email

Company engineer or technician

System administrator

Operators to be trained in the use and maintenance of the printer

Printer HP Stitch S1000 126in

General access & equipment unloading	Yes	No	Comments
Is there an easily accessible unloading area, with sufficient space to unload and maneuver the equipment?	<input type="checkbox"/>	<input type="checkbox"/>	
Has the route to the installation area been checked to meet all requirements (height, width, and clearance of ceilings, doorways, ramps, and corridors) and is the conveyance route clear?	<input type="checkbox"/>	<input type="checkbox"/>	
Is a power outlet available near the site where you plan to disassemble the crate (for the electric screwdriver used to disassemble the crate)?	<input type="checkbox"/>	<input type="checkbox"/>	
Have specialist movers been contracted to unload and move the equipment on the date required?	<input type="checkbox"/>	<input type="checkbox"/>	
Are the specialist movers aware of the specifications provided in this document?	<input type="checkbox"/>	<input type="checkbox"/>	

General access & equipment unloading	Yes	No	Comments
Is there enough space and manpower required to download the printer with the ramps?	<input type="checkbox"/>	<input type="checkbox"/>	
If a forklift is needed to unload the printer, has a suitable one been contracted for installation?	<input type="checkbox"/>	<input type="checkbox"/>	
If a forklift is needed, has the service part K4T88-67290 (forklift support) been ordered or provided by the reseller?	<input type="checkbox"/>	<input type="checkbox"/>	
Are there skates available to help position the crate?	<input type="checkbox"/>	<input type="checkbox"/>	
Is there a pallet jack available to help position the crate?	<input type="checkbox"/>	<input type="checkbox"/>	(Optional)
Will you install the printer on a second level or higher? If so, is there a suitable crane contracted for installation? Are the appropriate crane attachments available?	<input type="checkbox"/>	<input type="checkbox"/>	
Will the operator be available for the full amount of time required for the installation training (2.5 days)?	<input type="checkbox"/>	<input type="checkbox"/>	

Room layout and flooring	Yes	No	Comments
Is there sufficient space around the equipment?	<input type="checkbox"/>	<input type="checkbox"/>	
Has all room construction and painting been completed?	<input type="checkbox"/>	<input type="checkbox"/>	
Does the floor load-bearing capacity meet the specifications in the site preparation guide?	<input type="checkbox"/>	<input type="checkbox"/>	
Does the floor surface meet the specifications in the site preparation guide? If special reinforcements are necessary, are they completed?	<input type="checkbox"/>	<input type="checkbox"/>	

Safety requirements	Yes	No	Comments
Is there an emergency exit in the print production area, with easy access and free from any obstruction?	<input type="checkbox"/>	<input type="checkbox"/>	
Have the two fire extinguishers been fitted in the prescribed locations in the print production and storage areas? Is the print production fire extinguisher rated for electrical fire?	<input type="checkbox"/>	<input type="checkbox"/>	
Have strategic locations been allocated for the fixture and display of the appropriate safety warning signs?	<input type="checkbox"/>	<input type="checkbox"/>	
Does the area meet the Restricted Access Location requirements in the zone surrounding the printer?	<input type="checkbox"/>		(Required)
Do the users who operate the printer have appropriate technical training and experience necessary to be aware of the hazards to which they may be exposed in performing a task and to take appropriate measures to minimize the risks?	<input type="checkbox"/>		(Required)
Will printer operations be supervised at all times?	<input type="checkbox"/>		(Required)

Electrical installation	Yes	No	Comments
Has the site been prepared for the chosen power option? Configuration 1 branch circuit breaker: 4 poles, 25/30 A Configuration 2 branch circuit breaker: 3 poles, 32/40 A Configuration 3 branch circuit breaker: <ul style="list-style-type: none"> • Three-phase: 4 poles, 25/30 A • Single-phase control: 2 poles, 15/16/20 A Configuration 4 branch circuit breaker: <ul style="list-style-type: none"> • Three-phase: 3 poles, 32/40 A • Single-phase control: 2 poles, 15/16/20 A 	<input type="checkbox"/>		(Required)
Is the chosen power system within its nominal range? Configuration 1 Configuration 2 Configuration 3 Configuration 4	<input type="checkbox"/>		(Required)
Is the grounding conductor properly installed, as shown in the site preparation guide?	<input type="checkbox"/>		(Required)
Have you booked the services of an electrician for the day of installation?	<input type="checkbox"/>		(Required)
Is the electrician aware of all requirements and specifications highlighted in this document?	<input type="checkbox"/>		(Required)
Is the Power Distribution Unit (PDU) correctly installed?	<input type="checkbox"/>		(Required)
Are Residual-Current Circuit Breakers (RCCB), also known as Ground Fault Circuit Interrupters (GFCI), required by local laws? if so, have they a sensitivity of 100 mA or higher?	<input type="checkbox"/>	<input type="checkbox"/>	

Electrical configuration	Yes	No	Comments
Do you need an Uninterrupted Power Supply (UPS)? If so, is it correctly installed?	<input type="checkbox"/>	<input type="checkbox"/>	
No power cords are supplied with the printer; does the electrician understand that power cord(s) must be provided according to printer specifications and local laws?	<input type="checkbox"/>	<input type="checkbox"/>	
If local regulations specify that you must use electrical plugs to connect the printer to the power supply, does the electrician have the required plugs ready for installation?	<input type="checkbox"/>	<input type="checkbox"/>	

Networking requirements	Yes	No	Comments
Have network connections been supplied?	<input type="checkbox"/>	<input type="checkbox"/>	

Networking requirements	Yes	No	Comments
Do you have a LAN cable long enough to connect the printer to the network?	<input type="checkbox"/>	<input type="checkbox"/>	
Do you have an Internet connection?	<input type="checkbox"/>	<input type="checkbox"/>	

Equipment preparation	Yes	No	Comments
Is the air compressor or pressurized air line ready for the day installation?	<input type="checkbox"/>	<input type="checkbox"/>	
Have the correct supplies been ordered for deliver on or before the date of the printer's installation? Minimum requirements: 1 set of ink cartridges. Recommended: 1 set of ink cartridges, an extra set of ink cartridges, correct substrate for training purposes.	<input type="checkbox"/>	<input type="checkbox"/>	

RIP requirements	Yes	No	Comments
Has the HP Large Format Onyx Thrive RIP software (D9Z41B) been ordered, and is the computer to be used available with the required specifications?	<input type="checkbox"/>	<input type="checkbox"/>	
Has the HP Large Format Caldera Grand RIP software (L5E74C) been ordered, and is the computer to be used available with the required specifications?	<input type="checkbox"/>	<input type="checkbox"/>	
Has the HP Ergosoft RIP S1000 Color Edition software (7JC63A) been ordered, and is the computer to be used available with the required specifications?	<input type="checkbox"/>	<input type="checkbox"/>	
If neither of the HP Scitex RIPs is to be used, is there a computer available with a RIP application installed that supports the printer?	<input type="checkbox"/>	<input type="checkbox"/>	
Do you have a spectrophotometer that is compatible with the RIP?	<input type="checkbox"/>	<input type="checkbox"/>	

Environmental requirements	Yes	No	Comments
Have the temperature and humidity requirements been satisfactorily met in the print production area?	<input type="checkbox"/>	<input type="checkbox"/>	
Have the temperature and humidity requirements been satisfactorily met in the storage area?	<input type="checkbox"/>	<input type="checkbox"/>	
Is the print production area free from dirt and dust?	<input type="checkbox"/>	<input type="checkbox"/>	
Does the print production area have sufficient lighting?	<input type="checkbox"/>	<input type="checkbox"/>	
Have you met the ventilation and air conditioning requirements specified in this guide?	<input type="checkbox"/>		(Required)
Is there an exhaust installation that meets printer requirements?	<input type="checkbox"/>		(Required)

Color management questions	Answers
<p>Before buying this printer, did you already have a dye-sublimation printer?</p> <ul style="list-style-type: none"> • Model? • Ink brand? • Ink setup (CMYK, CMYK, ...)? • Which speed do you normally use? • Do you print DTF, transfer, or both? <p>And another dye-sublimation printer?</p> <ul style="list-style-type: none"> • Model? • Ink brand? • Ink setup (CMYK, CMYK, ...)? • Which speed do you normally use? • Do you print DTF, transfer, or both? 	
<p>Which RIP are you using, and which version?</p>	
<p>Which transfer papers do you use (brand, reference, weight)?</p>	
<p>Which textiles do you use (brand, reference) and for which main applications?</p>	
<p>Which transfer/heat-fixation system are you using (brand and model)?</p> <p>What settings do you use (temperature, time, speed, pressure)?</p> <p>Do you keep the printer and the heat press in the same room?</p>	

Color management questions	Answers
<p>If you use ICC profiles from your reseller or from another company, or generic profiles:</p> <ul style="list-style-type: none"> • Are you satisfied with the colors? • Would you like to be able to create your own profiles? 	
<p>If you create your own ICC profiles:</p> <ul style="list-style-type: none"> • Which measurement device do you have (brand and model)? • What was the date of your last calibration? • How would you rate your knowledge of color management, from 1 to 10? • Do you profile often? • How many different profiles do you use? 	

Date of site preparation completion

Site preparation guide edition number

2

Customer signature
