



HP Latex R Printer Series

Site Preparation Guide

© Copyright 2018–2019 HP Development Company, L.P.

Edition 3

Legal notices

The information contained herein is subject to change without notice.

The only warranties for HP products and services are set forth in the express warranty statement accompanying such products and services. Nothing herein should be construed as constituting an additional warranty. HP shall not be liable for technical or editorial errors or omissions contained herein.

Table of contents

1 Introduction	1
System configuration	1
Documentation and useful links	1
Site preparation overview	1
Customer responsibility	2
2 Site preparation	5
Planning for printer installation	5
Installation time schedule	5
System operation requirements	6
Air supply requirements (pneumatic spindle)	11
Room and spacial requirements	12
Designing the print production area	15
Computer and networking requirements	17
3 Shipment arrival preparation	21
Unloading area	21
Route from unloading site to installation site	21
Shipment items	22
Tools and manpower required for installation	22
Moving equipment	22
Waste disposal	26
4 Site Preparation Checklist	27
Instructions	27
Checklist	27

1 Introduction

System configuration

Your printer is supplied almost fully assembled and ready for the simple installation procedures described in detail in the installation guide. It comes complete with printheads and a printhead cleaner roll.

Documentation and useful links

The following documents are available for your printer, and can be downloaded from <http://www.hp.com/go/latexR1000/manuals> or <http://www.hp.com/go/latexR2000/manuals>, depending on your printer model:

- Site preparation guide and checklist
- Installation guide
- Introductory information
- User guide
- Legal information
- Limited warranty

Further information is available from <http://www.hp.com/go/latexR1000/support> or <http://www.hp.com/go/latexR2000/support>.

Videos and other training materials are available from:

- <http://www.hp.com/supportvideos>
- <http://www.youtube.com/HPPrinterSupport>
- <http://www.hp.com/go/latexR1000/training> or <http://www.hp.com/go/latexR2000/training>

See the Solutions website for information about new substrates, at <http://www.hp.com/go/latexR1000/solutions/> or <http://www.hp.com/go/latexR2000/solutions/>. A new Web-based Media Solutions Locator (<http://www.hp.com/go/mediasolutionslocator>) has been developed to collect available substrate configurations for latex printers.

Site preparation overview

This guide should assist in the following planning considerations:

- Modifications to the installation area
- Site accessibility
- Emergency exits
- Planning the print production area

- Mechanical, electrical and environmental specifications
- Computer and network connectivity
- Contracting a specialist mover with a forklift and/or suitable moving equipment; needed only if the site does not comply with the specifications to download the printer with the provided ramps
- Contracting an electrician
- Environmental health and safety

All information in this guide is provided on the assumption that installation planners and personnel are familiar with:

- Architectural and planning requirements
- Applicable laws, regulations and standards



NOTE: It is important to read the information provided in this guide thoroughly and ensure complete compliance with all installation and operation prerequisites, safety procedures, warnings, cautions, and local regulations.

Customer responsibility

Planning the site and printer environment

You are responsible for all preparations of the physical site, and you must complete the following tasks:

- Prepare the site for unloading. See [Unloading area on page 21](#).
- Make sure the route from the unloading site to the installation site meets specifications. See [Route from unloading site to installation site on page 21](#).
- Make sure you have the necessary equipment to handle the printer, as well as a specialist mover who is familiar with your site and the information provided in this guide. See [Moving equipment on page 22](#).
- Meet the requirements for second floor installations (if necessary). See [Above ground floor installation on page 24](#).
- Configure the building's electrical system used to power the printer to meet the printer's requirements and the Electrical Code requirements of the local jurisdiction of the country where the equipment is installed. A qualified electrician is required to power up the printer on the day of installation. See [Electrical configuration on page 6](#).
- Provide an adequate air supply for the pneumatic spindles. See [Air supply requirements \(pneumatic spindle\) on page 11](#).
- Meet temperature and humidity requirements and ensure proper ventilation for the printer. See [Air conditioning on page 13](#) and [Temperature and humidity on page 12](#).
- Material storage, handling, and disposal should be performed as per local laws. See the Safety Data Sheets at <http://www.hp.com/go/msds> for adequate handling and storage. Follow your Environmental Health and Safety processes and procedures.
- Supply all necessary emergency equipment. See [Safety installations on page 15](#).
- Ensure that the room in which the system is installed meets local environmental, health, and safety (EHS) guidelines and regulations.

RIP installation

If you have bought HP RIP software for your printer:

- You must ensure that a computer is available on which to install the RIP.
- For full functionality, you are recommended to ensure that the computer is connected to the Internet.
- You must ensure that the HP RIP software has arrived by the agreed date of printer installation.

If you have bought non-HP RIP software for your printer:

 **NOTE:** This guide does not provide information about your RIP solution.

- You must install the RIP on a suitable computer and ensure that it is fully functional by the agreed date of printer installation.
- For full functionality, you are recommended to ensure that the computer is connected to the Internet.
- You must ensure that a RIP specialist and a network specialist are present on the agreed date of printer installation.

Networking

You are responsible for all networking requirements, and you must complete the following tasks:

 **NOTE:** In order to perform remote support, the printer must have access to the Internet using the LAN connection.

- Have an adequate network ready for the day of installation. See [Computer and networking requirements on page 17](#).
- Provide a CAT-6 LAN cable to connect the printer to your LAN on the day of installation.

Printing supplies for testing and training

You are responsible for providing the following printing supplies:

- Eight ink cartridges

If you intend to install the White Ink Upgrade Kit: The two corresponding cartridges and the optimizer (no cartridges are supplied with the printer)

 **NOTE:** In addition, you are recommended to have a second set of ink cartridges, printheads, and one HP Latex Cleaning Roll, in case any replacements are needed.

- **If you intend to install the Roll Printing Kit:** Compressed air supply for the pneumatic spindle (see [Air pressure supply on page 11](#))
- Substrate for printing—preferably the substrate type that you plan to use most in future
- 10 liters of distilled water
- Self-adhesive vinyl substrate for the printhead alignment process, to be done during installation

Return the site preparation checklist

The checklist must be completed and returned to your reseller or service representative a minimum of two weeks before the day of installation.

 **NOTE:** Any delays during installation that are caused by an unprepared site will be charged to the customer. Take care that your site is properly prepared to ensure a smooth and easy installation.

Recycle the disposable ink bag and HP Latex Cleaning Roll

These items require disposal according to local regulations. For further information, please refer to the MSDS document about your printer's ink, available from www.hp.com/go/msds.

Recycle the printheads

The printheads require disposal according to local regulations. For further information, please refer to the MSDS document about your printer's ink, available from www.hp.com/go/msds. Within some countries covered by the 'HP Planet Partners Returns', HP is offering a recycling program. For full details of this program, please visit <http://www.hp.com/recycle/>.

Liquid waste disposal

Dispose of liquid waste in compliance with all applicable federal, state, and local regulations. Refer to "waste disposal" in the user guide. HP can provide a typical Waste Profile Datasheet to assist you with disposal decisions.

2 Site preparation

Planning for printer installation

This chapter covers the main topics related to efficient planning and preparation of the site. Take into consideration any structural modifications required and the time required for submission and approval of plans to the relevant local authorities. Secure temporary storage for the shipping crate prior to equipment installation may also be necessary.

⚠ CAUTION: All cables connected to the printer should be contained within suitable conduits; these may be overhead or channeled into the floor, as appropriate. Tripping over loose wires or cables can cause personal injury and/or damage to the equipment.

Installation time schedule

The best method to ensure a smooth and trouble-free installation process is proper site preparation. The following time schedule estimate is based on the assumption that all system components have been delivered in proper working order and all site preparation and planning requirements have been met and completed, in accordance with the specifications provided in this guide. The installation process is divided into two phases:

Installation time schedule

	Time to completion
Installation and system configuration	2.5 full working days
Operation and maintenance training	2 full working days

Although the optimal time schedule requires approximately 4 working days, it may be necessary to schedule additional time for either phase. Please plan ahead for any special circumstances that may occur during the installation process, and do not plan for production during installation and training.

If the RIP software is bought from HP, the training will cover the normal use of the RIP. The following aspects of RIP usage will be covered:

HP Scitex ONYX Thrive RIP v12.1 or later

- RIP-Queue
- Configure the printer (Quickset, Device output, Substrate, Page size, Properties)
- Main items of the Job Editor (Printer and substrate selection, Preview and size, Tiling setup, Color correction, Print)

The Media Manager will not be covered.

HP Scitex CALDERA GRAND RIP v11.1 or later

- Server Administration (Server, Configure, Connection)
- GrandRIP+ (Main, Tool, Settings)
- Spooler
- Image Work Directory (Image positioning and scale setting on the page, and so on)

Profile creation will not be covered.

System operation requirements

Electrical configuration

NOTE: An electrician is required for the setup and configuration of the building electrical system used to power the printer and also for printer installation. Make sure that your electrician is appropriately certified according to local regulations and supplied with all the information regarding the electrical configuration.

The HP Internal Print Server can be powered with a single-phase line that can be used with an Uninterruptible Power Supply (UPS)*. The UPS must be rated to meet the power requirements of the printer, and should be in accordance with the wiring standards of the country of installation.

* If you intend to split the input power between a 3-phase branch and a 1-phase (UPS) branch, you should use a UPS with a minimum specification of 500 VA and 250 W.

The printer requires the following electrical components to be supplied and installed by the customer, according to the Electrical Code requirements of the local jurisdiction of the country of installation.

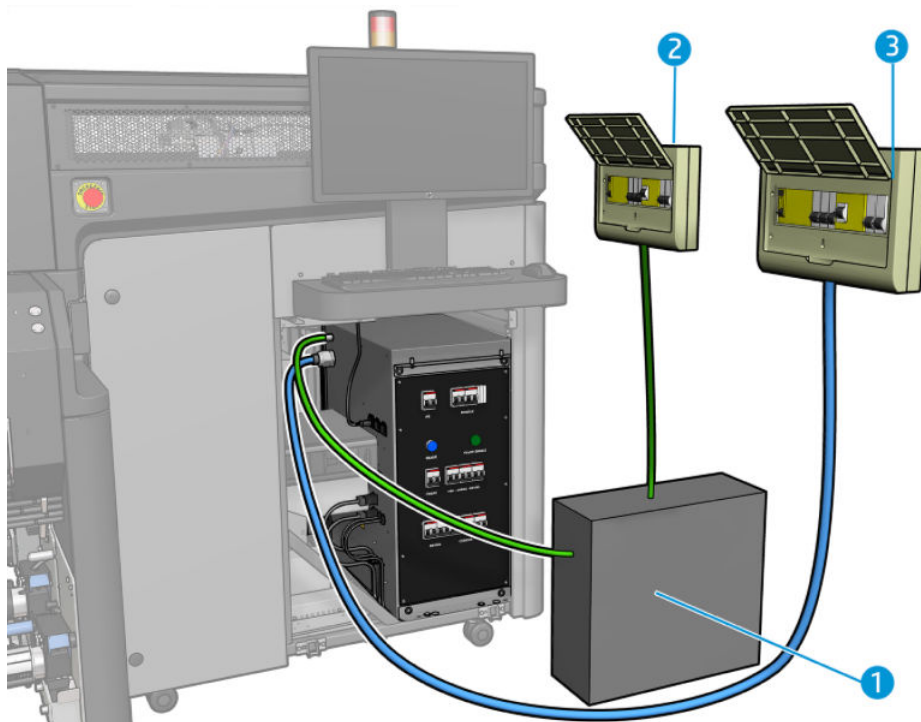

1. Uninterruptible Power Supply (UPS) for single-phase control line (optional)

 **NOTE:** The HP Internal Print Server power can be obtained by making a connection inside the electrical cabinet.

2. Power Distribution Unit (PDU) including single-phase branch circuit breaker (optional)
3. Power Distribution Unit (PDU) including three-phase branch circuit breaker depending on the power configuration

 **NOTE:** Remember that you are required to follow the local laws, regulations, and standards that apply to the electrical installation of your printer.

 **NOTE:** The printer is not supplied with any power cable.

Power distribution unit (PDU)

The PDU must be rated to meet the power requirements of the printer, and should be in accordance with the Electrical Code requirements of the local jurisdiction of the country where the equipment is installed.

Power specifications

Configuration 1: 380–415 V line-to-line three-phase configuration

Three-phase specifications

Number of power wires	5 (L1/L2/L3/N/PE)
Input voltage (line to line)	380–415 V~ ($\pm 10\%$)
Input frequency	50/60 Hz
Maximum load current (per phase)	35 A

Branch circuit breaker specifications

Three-phase	4 poles, 40/50 A
-------------	------------------

AC three-phase power cable specifications

Configuration	5 wires, L1/L2/L3/N/PE
Wire	Strained Cu32 minimum, 10 mm ² or 8 AWG
Terminals	Lines, ferrule terminals, PE, M8 ring terminal
External diameter range	22.0–33.0 mm

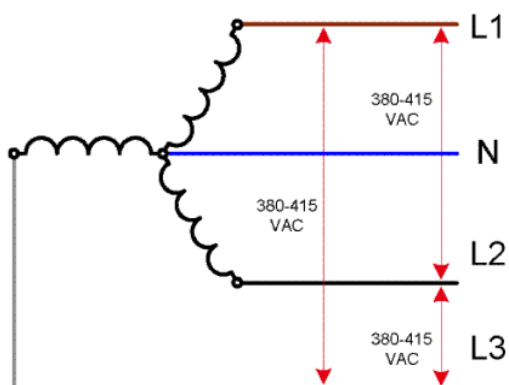

Configuration 2: 200–240 V line-to-line three-phase configuration

Three-phase specifications

Number of power wires	4 (L1/L2/L3/PE)
Input voltage (line to line)	200–240V ($\pm 10\%$)
Input frequency	50/60 Hz
Maximum load current (per phase)	56 A

Branch circuit breaker specifications

Three-phase	3 poles, 63/70 A
-------------	------------------

AC three-phase power cable specifications

Configuration	4 wires, L1/L2/L3/PE
Wire	Strained Cu minimum, 10 mm ² or 6 AWG
Terminals	Lines, ferrule terminals, PE, M8 ring terminal
External diameter range	22.0–33.0 mm

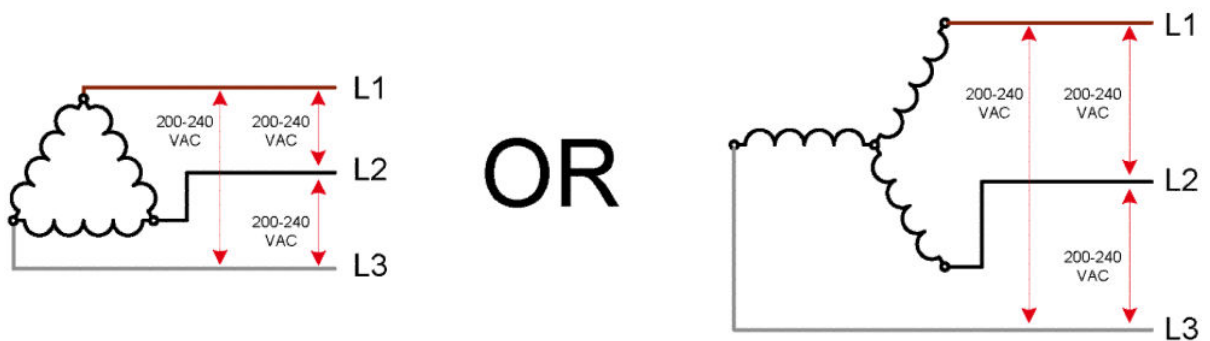

Configuration 3: 380–415 V line-to-line three-phase configuration with single-phase control

Specifications

	Three-phase line	Single-phase control
Number of power wires	5 (L1/L2/L3/N/PE)	3 (L/N/PE)
Input voltage (line to line)	380–415 V \sim (-10%)	100–240 V ($\pm 10\%$)
Input frequency	50/60 Hz	50/60 Hz
Maximum load current (per phase)	35 A	10 A

Branch circuit breaker specifications

Three-phase	4 poles, 40/50 A
Two-phase control	2 poles, 15/16/20 A

AC Power cable specifications

	Three-phase line	Single-phase line
Configuration	5 wires, L1/L2/L3/N/PE	3 wires, L/N/PE
Wire	Strained Cu minimum, 10 mm ² or 8 AWG	Strained Cu minimum, 1.5 mm ² or 16 AWG
Terminals	Lines, ferrule terminals, PE, M8 ring terminal	Lines, ferrule terminals, PE, M4 ring terminal
External diameter range	22.0–33.0 mm	5.0–11.0 mm

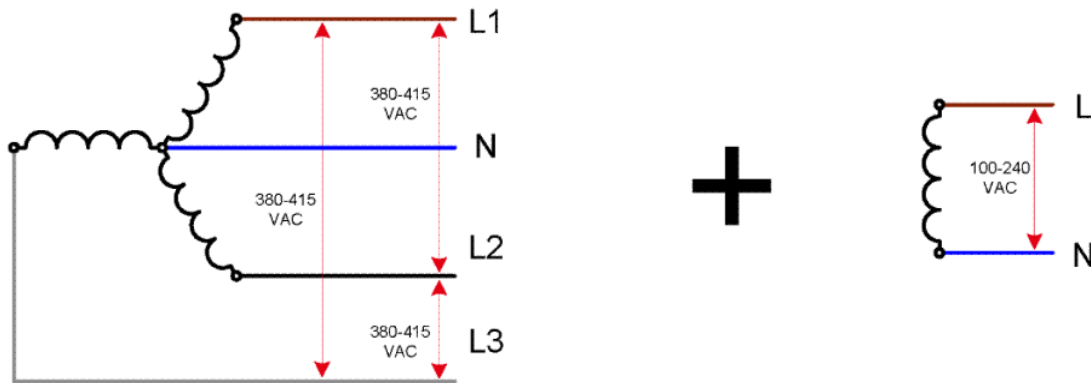

Configuration 4: 200–240 V line-to-line three-phase configuration with single-phase control

Specifications

	Three-phase line	Single-phase control
Number of power wires	4 (L1/L2/L3/PE)	3 (L/N/PE)
Input voltage (line to line)	200–240 V ($\pm 10\%$)	100–240 V ($\pm 10\%$)
Input frequency	50/60 Hz	50/60 Hz
Maximum load current (per phase)	56 A	10 A

Branch circuit breaker specifications

Three-phase	3 poles, 63/70 A
Two-phase control	2 poles, 15/16/20 A

AC Power cable specifications

	Three-phase line	Single-phase line
Configuration	4 wires, L1/L2/L3/PE	3 wires, L/N/PE
Wire	Strained Cu minimum, 10 mm ² or 8 AWG	Strained Cu minimum, 2.5 mm ² or 16 AWG
Terminals	Lines, ferrule terminals, PE, M8 ring terminal	Lines, ferrule terminals, PE, M4 ring terminal
External diameter range	22.0–33.0 mm	5.0–11.0 mm

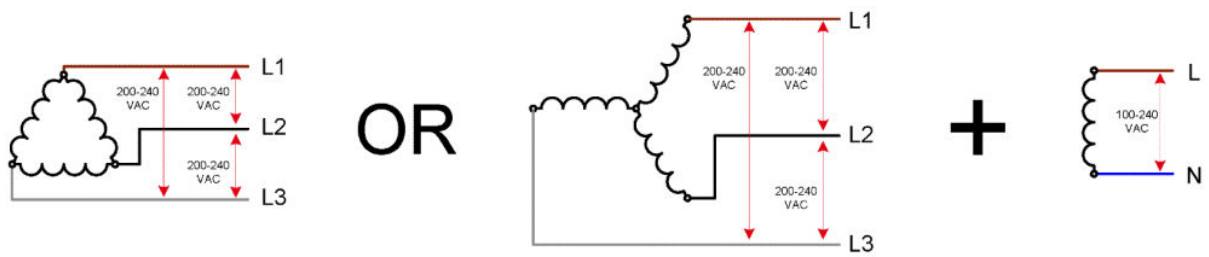

Circuit breakers (required)

The circuit breakers must meet the requirements of the printer and should be in accordance with the Electrical Code requirements of the local jurisdiction of the country where the equipment is installed.

The printer requires one or two branch circuit breakers, depending on the installation.

NOTE: The printer has built-in Residual-Current Circuit Breakers (RCCB), also known as Ground Fault Circuit Interrupters (GFCI), with 30 mA sensitivity. If local laws require an external RCCB or GFCI for earth fault protection, install a device with sensitivity of 100 mA or higher, with appropriate rated current for the supply configuration, and ensure that other protective devices for earth fault protection upstream from the one supplying the printer are always greater than the one selected for the printer.

WARNING! The rated short-circuit breaking capacity of the circuit breakers in the printer is 6 kA. This shall be coordinated with the branch circuit breaker in PDU (Power Distribution Unit) if so required by the Electrical Code of the local jurisdiction.

WARNING! Ensure that the printer's built-in Residual-Current Circuit Breakers (RCCB) or Ground Fault Circuit Interrupters (GFCI) operate in the case of a current leakage fault to the product chassis, even when an isolation device (such as an isolating transformer) will be used to supply power to the printer.

Power cables

No power cable is provided with the printer. The cables that you use must meet the minimum specifications for the chosen configuration explained for each configuration.

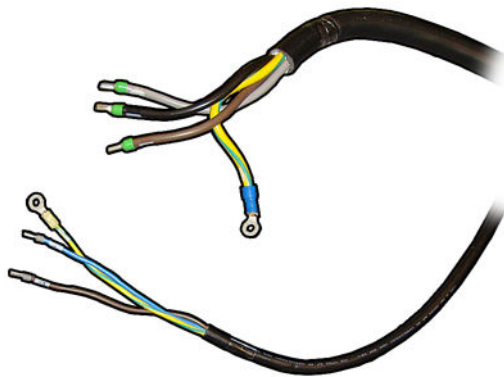

PE connections for mains power should be made through an M8 stub.

The power cable for PC power can be routed from above the right of the top cover; it can be routed from the ceiling.

Powerline disturbances

Reliable operation of your printer depends on the availability of relatively noise-free AC power.

- In order to ensure optimum performance and reliability, your printer should be protected from variations in line voltage, which are common to production printing environments. Lighting, line faults, or the power switching commonly found in machinery in factory environments can generate line transients that far

exceed the peak value of the applied voltage. If not reduced, these micro-second pulses can disrupt system operation.

- If the power line supplying the installation site is a public low voltage line shared with other users, the power line impedance Z_{max} must be less than 51 m Ω , to comply with European standard EN/IEC 61000-3-11. If other users on the same power line report any flickering of incandescent light bulbs, contact your electricity supplier to verify that the power network has an impedance lower than the one specified above.
- This equipment complies with EN/IEC 61000-3-11 provided that the short-circuit power S_{sc} is greater than or equal to 3MVA at the interface point between the user's supply and the public system. It is the responsibility of the installer or user of the equipment to ensure, by consultation with the distribution network operator if necessary, that the equipment is connected only to a supply with a short-circuit power S_{sc} greater than or equal to 3MVA.
- It is recommended to include overvoltage (OVP) and transient protection on the power supply to the printer.
- All electrical noise generating equipment, like fans, fluorescent lighting, and air-conditioning systems, should be kept separate from the power source used for your printer.

Grounding

The printer must be connected to a good quality, dedicated ground line in order to avoid electrical risk. Please note your obligation to comply with the National Electrotechnical Code (NEC) in the county of installation.

The following grounding tasks must be fulfilled to meet the site preparation requirements:

- Grounding wires should be insulated and at least equal in size to the phase conductors.
- Ground impedance must be less than 0.5 Ω .
- The installation of a single point and dedicated ground.
- Power stabilizer equipment that is supplied by three uninterrupted phase wires and one uninterrupted copper ground wire from the main building service panel. These should run in the same conduit and should be at least equal in size to the phase wires.

Air supply requirements (pneumatic spindle)

 **NOTE:** Only for printers with the HP Latex R Printer Series Roll Printing Kit Accessory.

Air pressure supply

The pneumatic spindle requires an air compressor or pressurized air line that must be provided by the customer.

 **TIP:** HP recommends that you use an air compressor with a pressure gauge that measures in bars.

Air supply specifications

	Specification
Air pressure	5.5 bar (80 psi) (required)
Minimum airflow	30 liters/minute (1.06 cubic feet/minute)
Lubricator (not required)	Not recommended
Air filter (recommended)	Recommendation: 5 μ m, auto-drain, 99.97% coalescing efficiency
Regulator (required)	Regulator with pressure gauge

Pneumatic connector

The printer comes with an air gun that you must attach to your air supply. In order to connect your air supply to the air gun, you must meet the following requirements:

- 6.35 mm (0.25 in) female connector, BSP or NPT thread
- PTFE tape to secure the connection and prevent air leaks

⚠ WARNING! Take care when using the air gun. When used for cleaning purposes, make sure to use it according to the local regulations since additional safety provisions may apply

Room and spacial requirements

Temperature and humidity

The temperature, humidity, and temperature gradient during operation and during storage must be kept within the standard ranges to ensure the correct operation of the printer. Failure to keep these environmental conditions within the standard ranges may cause image quality problems or damage sensitive electronic components.

Printer environmental specifications

	Temperature range	Humidity range	Temperature gradient
Operating for optimal print quality	20 to 25°C (68 to 77°F)	30 to 60% Relative Humidity	10°C/h (50°F/h) or less
Operating for standard printing	15 to 30°C	20 to 70%	10°C/h (50°F/h) or less
Not operating (in transport or storage), ink in tubes	5 to 55°C (41 to 131°F)	90% Relative Humidity at 55°C (131°F)	10°C/h (50°F/h) or less
Not operating (in transport or storage), no ink in tubes	-25 to 55°C (-13 to 131°F)	90% Relative Humidity at 55°C (131°F)	10°C/h (50°F/h) or less

Maximum operating altitude: 3000 m (10000 ft)

In addition to controlling the temperature, humidity, and temperature gradient, there are other environmental conditions that must be met during site preparation.

- Do not install the printer where it will be exposed to direct sunlight or a strong light source.
- Do not install the printer in a dusty environment. Remove any accumulated dust before moving the printer into the area.

Ventilation

Ensure that the room in which the system is installed meets local environmental, health, and safety (EHS) guidelines and regulations.

Fresh air ventilation is needed to maintain comfort levels. For a more prescriptive approach to adequate ventilation, you could refer as guidance to the latest edition of the ANSI/ASHRAE (American Society of Heating, Refrigerating and Air-Conditioning Engineers) document 62.1: *Ventilation for Acceptable Indoor Air Quality*.

Adequate ventilation needs to be provided to ensure that potential airborne exposure is adequately controlled according to Safety Data Sheets. Consult the Safety Data Sheets available at <http://www.hp.com/go/msds> to identify chemical ingredients of your ink consumables.

Airborne materials can be readily identified and quantified by using established indoor air quality testing protocols. HP performs these assessments during the development phase for all products.

HP testing shows that during printer operation, the concentrations of airborne contaminants measured in the workspace are consistently well below key occupational exposure limits. This observation is based on exposure assessments that model very active productivity at customer facilities. Customers should recognize that actual levels in their facilities are dependent on workspace variables they control such as room size, ventilation performance and duration of equipment use.

HP's assessment concluded, based on the available scientific information, that airborne materials are not expected to present a health hazard by providing a minimum of 10 ACH (air changes per hour) of fresh air ventilation and a minimum room volume of:

- 120 m³ (4238 ft³) HP Latex R1000 Printer
- 185 m³ (6533 ft³) HP Latex R2000 Printer

These specifications are valid for the following conditions: one HP printer using a black area fill plot at 100 m²/h (1076 ft²/h), 3 passes, 80% of ink, assuming 8 hours of printing exposure time a day. If there is more equipment in the room, or different conditions the ventilation rate should be recalculated accordingly.

In addition to the workspace benefit provided by general room ventilation, intense use of this printer system in some customers' facilities may require the use of localized ventilation in order to provide a readily acceptable working environment. This installation of localized exhaust for a printer frequently enables the capture of airborne contaminants near their source of generation, and subsequent allows their efficient removal from the building through contained, and relatively low volume air flow. A workspace health and safety professional can provide guidance on the design and use of this auxiliary ventilation equipment.

Air conditioning

In addition to fresh air ventilation, to avoid health hazards, also consider maintaining workplace ambient levels by assuring the climatic operating conditions specified in this document (see [Printer environmental specifications on page 12](#)) to avoid operators' discomfort and equipment malfunction. Air conditioning in the work area should take into account that the equipment produces heat. Typically, the printer's power dissipation is:

- 9 kW (30.7kBTU/h) HP Latex R1000 Printer
- 11 kW (37.5kBTU/h) HP Latex R2000 Printer

Air conditioning should meet local environmental, health, and safety (EHS) guidelines and regulations.

 **NOTE:** The air conditioning units should not blow air directly onto the equipment.

Load bearing

The load-bearing characteristics of the floor in the print production area must be sufficient to withstand the weight of your printer. To calculate the load bearing characteristics of the print production floor, you must consult a structural engineer.

	HP Latex R1000 Printer (64")	HP Latex R2000 Printer (98")
Printer weight with crate	2400 kg (5291 lb)	2800 kg (6173 lb)
Printer weight without crate	1400 kg (3086 lb)	1600 kg (3527 lb)

Your printer has four wheels in the main structure, two wheels in both side structures (eight total) to move the printer, and three feet that must be lowered to touch the ground and support the printer.

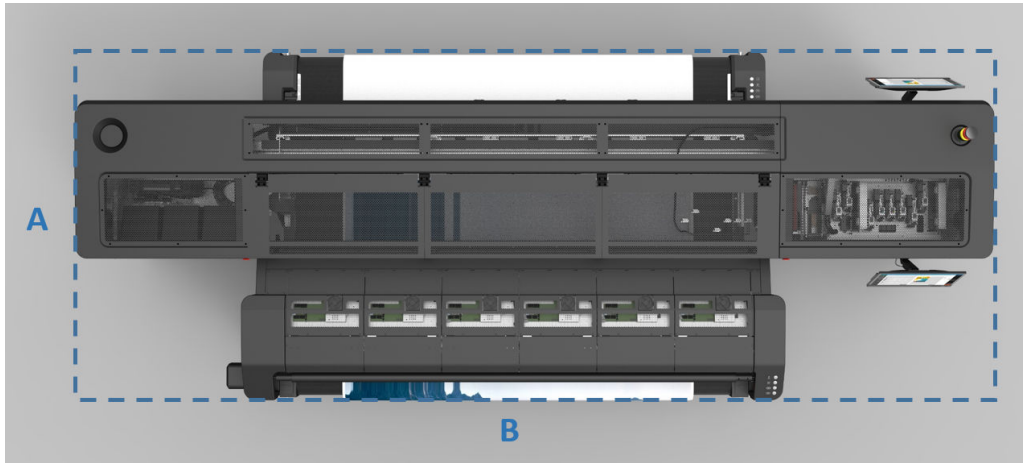

In the table below, the number or letter in the left column corresponds to the diagram above.

	HP Latex R1000 Printer (64")	HP Latex R2000 Printer (98")
A	2.04 m (6ft 8.31 in)	2.04 m (6ft 8.31 in)
B	4.2 m (13ft 9.35 in)	5.1 m (16ft 8.79 in)

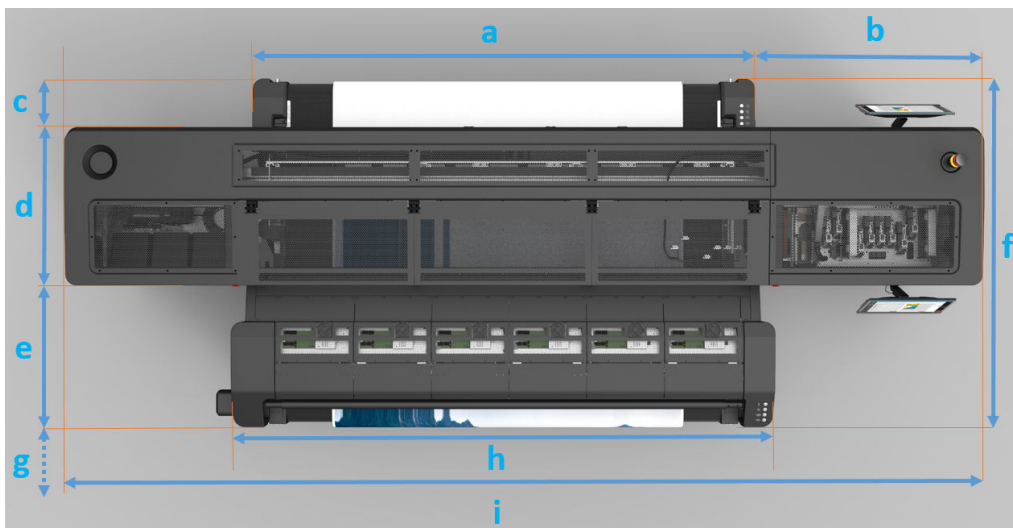

In the table below, the number or letter in the left column corresponds to the diagram above.

	HP Latex R1000 Printer (64")	HP Latex R2000 Printer (98")
a	2.06 m (6ft 9.1 in)	2.95 m (9ft 8.26 in)
b	1.19 m (3ft 10.85 in)	1.19 m (3ft 10.85 in)
c	0.34 m (1ft 1.39 in)	0.34 m (1ft 1.39 in)
d	0.88 m (2ft 10.65 in)	0.88 m (2ft 10.65 in)
e	0.82 m (2ft 8.28)	0.82 m (2ft 8.28)
f (c+d+e)	2.04 m (6ft 8.31 in)	2.04 m (6ft 8.31 in)
g (when curing model is open)	0.55 m (1ft 9.65 in)	0.55 m (1ft 9.65 in)
h	2.2 m (7ft 2.54 in)	3.08 m (10ft 1.26 in)
i	4.21 m (13ft 9.75 in)	5.1 m (16ft 8.79 in)

Height with printer status beacon	1.75 m (5ft 8.9 in)	1.75 m (5ft 8.9 in)
Height without printer status beacon	1.49 m (4ft 10.66 in)	1.49 m (4ft 10.66 in)

Floor surface

The floor surface should have the following characteristics:

- Horizontal surface
- Solid, smooth, and level
- No holes or indentations
- Static-free surface (no carpet)
- Easy to clean
- Durable
- Free from strong vibrations
- Concrete

Lighting

Whenever your printer is in operation, the print production area should be well lit to provide the operator with optimal conditions for checking the color and alignment during print production. If there is not enough natural light, artificial lighting will be required.

Designing the print production area

Safety installations

Fire fighting equipment

You must provide two fire extinguishers for the site. Make sure the extinguishers are placed where they are easily accessible in case of fire.

- A fire extinguisher certified for electrical fires must be in the print production area.
- A fire extinguisher must be placed in the substrate storage area, due to the large amount of solid combustibles (substrates).

Emergency exits and first aid stations should also be considered.

Optimal room layout

Your printer requires enough space to perform common tasks.

Your printer has the following dimensions:

Physical specifications

	HP Latex R1000 Printer (64")	HP Latex R2000 Printer (98")
Weight	1400 kg (3086 lb)	1600 kg (3527 lb)
Width	4.21 (13ft 9.75 in)	5.1 m (16ft 8.79 in)

Physical specifications (continued)

Depth	2.04 m (6ft 8.31 in)	2.04 m (6ft 8.31 in)
Height	1.747 m (5ft 8.78 in)	1.747 m (5ft 8.78 in)

IMPORTANT: The following diagram shows only dimensions for optimal printing layout, to meet ventilation requirements follow the instructions in the corresponding chapter. See [Air conditioning on page 13](#).

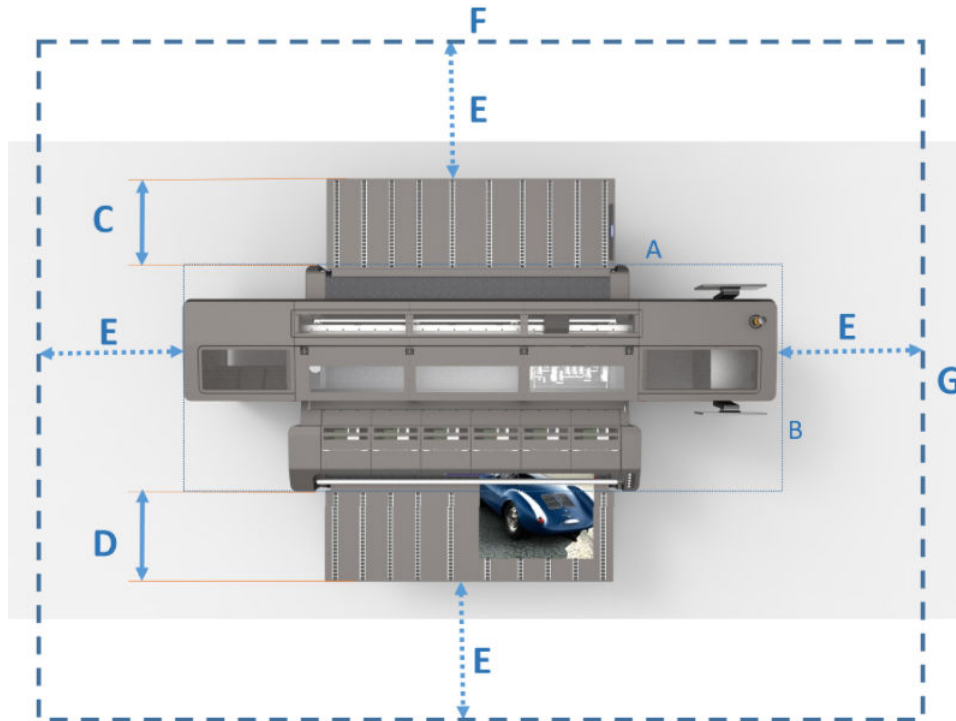

In the table below, the letter in the left column corresponds to the room layout illustration above.

	HP Latex R1000 Printer (64")	HP Latex R2000 Printer (98")
A	2.04 m (6ft 8.31 in)	2.04 m (6ft 8.31 in)
B	4.21 m (13ft 9.75 in)	5.1 m (16ft 8.79 in)
C	0.65 m (2ft 1.59 in)	0.65 m (2ft 1.59 in)
D	0.94 m (3ft 1 in)	0.94 m (3ft 1 in)
E	1.2 m (3ft 11.24 in)	1.8 m (5ft 9.05 in)
F	6.61 m (21ft 8.24 in)	8.7 m (28ft 6.51 in)
G	6.03 m (19ft 9.4 in)	7.23 m (23ft 8.65 in)

NOTE: The extension tables measure 0.94 m (3 ft 1 in), when using them it is recommended to add this dimension to the recommended space shown in the above table, to all sides of the printer.

NOTE: If very large substrate is to be used, make sure to take it into account when choosing where to install the printer.

The ceiling of the room should be at a minimum height of 3 m (9 ft 8.43 in) above the floor.

WARNING! The zone surrounding the printer should be considered a restricted access area and signaled accordingly. Only trained personnel should be operating within this area.

 **WARNING!** The printer should not be covered with any substrate, especially not rigid substrate.

Storage area for materials

When planning a storage area for materials used with the printer, thought should not only be given to safety and convenience, but also to the fact that if inks and substrates are not stored in the appropriate temperature and humidity conditions, print results may be adversely affected.

The storage area should be of sufficient size to accommodate adequate stocks of substrate rolls and inks. The storage area should be located near the print production area to minimize the lifting and maneuvering of heavy materials and to finish and package prints for shipment or distribution.

The storage area should have a covered roof. It should be dry, well ventilated and able to provide protection from direct light. It is important that temperature and humidity are maintained within values specified for each substrate type.

 **NOTE:** Allow enough (environmentally controlled) space to store the printheads. This is indicated by the directional arrows on the printhead boxes.

Storage conditions for ridged substrates

Rigid-cut sheet substrate should be stored flat and not stored for long periods before use. Any warping of this substrate will increase the likelihood of the carriage striking it during printing, or substrate feed problems. Due to the tendency of synthetic rigid substrate to build up an electrostatic charge, ESD abatement measures such as raising the relative humidity in the room or draping copper grounding tinsel over the stored substrate may be necessary.

Inks and solvent containers must be properly sealed and stored in the upright position in a flame-proof storage cabinet.

 **WARNING!** Do not permit smoking or open flames in the print production or storage areas, and prominently display the appropriate warning signs.

 **WARNING!** To avoid electrical shocks or burns caused by the use of wrong type of fire extinguisher, make sure your fire extinguisher has been approved for use on electrical fires.

 **NOTE:** It is recommended that substrate remain in their sealed wrapping material when placed in storage. It is advisable to move them from the storage area to the print production area at least 24 hours before use, so that they may reach the required moistness and operating temperature.

Storage conditions for substrate rolls

Keep substrate rolls in their sealed wrapping material while they are placed in storage.

Store substrate rolls vertically to avoid the migration of plasticizers in some materials.

Move substrates from the storage area to the print production area at least 24 hours before use, so that they can reach the required moistness and operating temperature.

 **NOTE:** HP substrate rolls have a 12 month warranty when the substrate rolls are stored under optimal conditions. The warranty term varies depending upon the material and the manufacturer.

Computer and networking requirements

Requirements

- Network functionality requires an **Outbound** connection to all the following addresses.

Remote domain	Protocol and port
hp.com	https 443
heleni.me	https 443

 **NOTE:** If needed, please instruct the customer IT to create routing rules that route around the proxy for these addresses.

- A minimum upload speed of 5 Mb/s is required.

HP provides the following system components:

HP provided components

- HP Internal Print Server
 - PC and power cord
 - PC LAN card connections: 2 Ethernet ports, one for the e-box LAN cable to connect the printer to the PC, and the other to connect to the network
 - 2 monitor and power cords
 - Windows 10 Embedded
 - HP Internal Print Server software

Customer provided components

- Ethernet LAN (minimum 1 Gb/s) connection
- RIP station and software
- CAT-6 LAN cable long enough to connect the printer to the network

RIP requirements



There are two RIPs offered by HP that may be used with the printer:

- HP Scitex ONYX Thrive RIP v12.1 (or later): product number D9Z41A
- HP Scitex Caldera Grand RIP v11.1 (or later): product number L5E74A

The software and hardware requirements of these RIPs are as follows.

HP Scitex ONYX Thrive RIP v12.1 or later

- Main Workstation requirements:
 - Operating System: Microsoft Windows 7 Professional operating system 64-bit or newer (32-bit not supported)
-  **NOTE:** 32-bit operating systems have a hardware limit of 4 GB of RAM. It is recommended you use 64-bit operating systems for high volume workflows.
- Processor: Multi-core processor
 - RAM: 8 GB minimum (4 GB / core recommended)
 - Hard Drive: 500 GB (7200 rpm) (250 GB+ free space)

- Network Connectivity: Gigabit Ethernet for TCP/IP printers
-
-  **NOTE:** Firewall and antivirus must be disabled or configured to allow ONYX applications and printer ports (515, 1947, 8889, 9100, and 10000). There may be other ports needed, please see device manufacturer for details.
-
- Monitor: 1280 × 1024 pixels, 16-bit color
 - USB port for security key
 - DVD-ROM drive
- Distributed Workstation requirements:
 - Microsoft Windows 7 Professional operating system (SP1 or higher) Windows 8 Professional
-
-  **NOTE:** 32-bit operating systems have a hardware limit of 4 GB of RAM. It is recommended you use 64-bit operating systems for high volume workflows.
-
- Processor: Intel Core i7 or equivalent
 - RAM: 4 GB/processing core
 - Hard Drive: 250 GB free
 - Network Connectivity: Gigabit Ethernet for TCP/IP printers
-
-  **NOTE:** Firewall and antivirus must be disabled or configured to allow ONYX applications and printer ports (515, 1947, 8889, 9100 and 10000). There may be other ports needed, please see device manufacturer for details.
-
- Thrive Production Manager requirements:
 - Macintosh, Windows PC or Mobile Device with HTML web browser
- For the latest details of Onyx configuration, see <http://www.onyxqfx.com/system-specifications/>.

HP Scitex CALDERA GRAND RIP v11.1 or later (minimum configuration)

- Linux:
 - Operating System: Caldera Debian x64 (recommended)
 - Processor : Intel Core i3, i5, or i7
 - RAM : 4 GB or 8 GB (recommended). Minimum 1 GB per core, recommended at least 2 GB per core.
 - HDD : 250 GB
 - Monitor / Videocard : 1280 × 1024 resolution
- Mac:
 - Operating System : OS 10.8, 10.9, 10.10
 - Hardware : Intel Core i3 ,i5, or i7 based Mac mini, iMac, or Mac Pro. MacBook Air and MacBook Pro not supported. !PPC based hardware (G5, G4, ...) not supported.
 - 4 GB or more. Minimum 1 GB per core, recommended at least 2 GB per core.
 - HDD : 250 GB
 - Monitor: Resolution at least 1280 × 1024

For the latest details of Caldera configuration, see:

- http://www.caldera.eu/en/support.php?page=operating_system
- <http://www.caldera.com/product/grandrip/>

External color profiling

In order to build color profiles for your printer, an external color sensor is needed. Make sure to choose an external spectrophotometer that is compatible with your RIP.

During the installation training, it is the customer's responsibility to have a RIP specialist available to create color profiles.

3 Shipment arrival preparation

Unloading area

A suitable unloading area will need to be designated that will be easily accessible to the delivery truck. This will require sufficient space to unload the large crate in which your printer is shipped. When planning this area, consider the following:

- Height and width of entrance to unloading area
- Ramps used to access the unloading area
- Height and size of unloading dock (if applicable)

Route from unloading site to installation site

The route between the unloading area of the printer and the installation site, including any corridors and doorways through which the printer must be transported, is important to proper site preparation and must be planned before the arrival of the printer. This pathway must be clear when the printer arrives. Regarding ground floor room access, transport of the bulky printer components requires:

Doorway, ceiling and corridor specifications

	Printer	Crate
Minimum doorway width	2,05 m (6ft 8.71in)*	2.4 m (7ft 10.49 in)
Minimum ceiling height	2.25 m (7ft 4.58 in)	2.3 m (7ft 6.55 in)
Minimum corridor width	2,05 m (6ft 8.71 in)	2.4 m (7ft 10.49 in)
Minimum corridor width for a 90° turn	4.4 m (14ft 5.23 in)	4.4 m (14ft 1.29 in)

* If you don't have this doorway width, the printer can be partially disassembled, and is able to pass between a width of 1.91 m (6ft 3.2 in).

⚠ WARNING! After being removed from the crate, the printer can be moved up or down a ramp of no more than 3% inclination.

💡 TIP: Decide when you will remove the printer from the crate. It is recommended that the shipping crate be unpacked as close as possible to the printer's final destination. Usually, the printer is removed from the crate before moving it to the installation site.

Disassembling the crate requires an electric screwdriver that must be plugged into a power outlet, so make sure that a power outlet is available near the site where you plan to disassemble the crate.

Shipment items

All printer components will arrive in a single crate. The dimensions and weight of the crate and printer are as follows:

Printer and crate physical specifications

	Width	Depth	Height	Weight
HP Latex R1000 Printer (64")				
Crate (printer inside)	4.425 m (14ft 6.21 in)	2.192 m (7ft 2.3 in)	2.150 m (7ft 0.65 in)	2400 kg (5291 lb)
Printer	4.21 (13ft 9.75 in)	2.04 m (6ft 8.31 in)	1.747 m (5ft 8.78 in)	1400 kg (3086 lb)
HP Latex R2000 Printer (98")				
Crate (printer inside)	5.320 m (17ft 5.45 in)	2.192 m (7ft 2.3 in)	2.150 m (7ft 0.65 in)	2800 kg (6173 lb)
Printer	5.1 m (16ft 8.79 in)	2.04 m (6ft 8.31 in)	1.747 m (5ft 8.78 in)	1600 kg (3527 lb)

Tools and manpower required for installation

The installation process requires 5 capable people if ramps are used. If a forklift is used, only 2 people are needed, usually the installer and the operator. Additionally, a certified electrician is required to configure the electrical system.

Check with the installation specialist before delivery to make sure you do not have to supply any tools.

Moving equipment

Ground floor installation

It is highly recommended to lower the printer with the ramps as indicated in the installation guide. In exceptional cases, where ramps cannot be used due to a physical barrier, follow the alternative instructions indicated carefully.

⚠ CAUTION: Unloading and moving the printer and all system components is the customer's responsibility and not HP's. Failure to provide the required moving and lifting apparatus could result in personal injury or damage the printer during installation.

Lower the printer with ramps

- Minimum room space to lower 5.2 m beside the crate, 8.2 m total
- Minimum manpower: 5 people
- Flat floor or max 3% inclination

The recommended way to lower the printer is by using the ramps provided. If this is not possible, you can use a forklift to lower the printer.

The use of specialist moving and lifting equipment is required during the unloading, unpacking, and installation of your printer.

Advanced booking for the services of a machinery moving contractor/rigger must be made. It is important to confirm that the hired moving specialist and moving equipment will be available when the printer is delivered.

The following equipment is recommended:

- Wide, heavy-duty forklift (required)

Forklift specifications

Printer	Weight	Fork length	Inner distance between forks to move crate	Inner distance between forks to move printer
R1000	min. 3000 kg (6614 lb)	2 m (79 in)	Maximum width of the forks	750 mm (29.5 in)
R2000	min. 4000 kg (8818 lb)			910 mm (35.8 in)

 **IMPORTANT:** Look at the information on the structure labels to ensure position and distance.

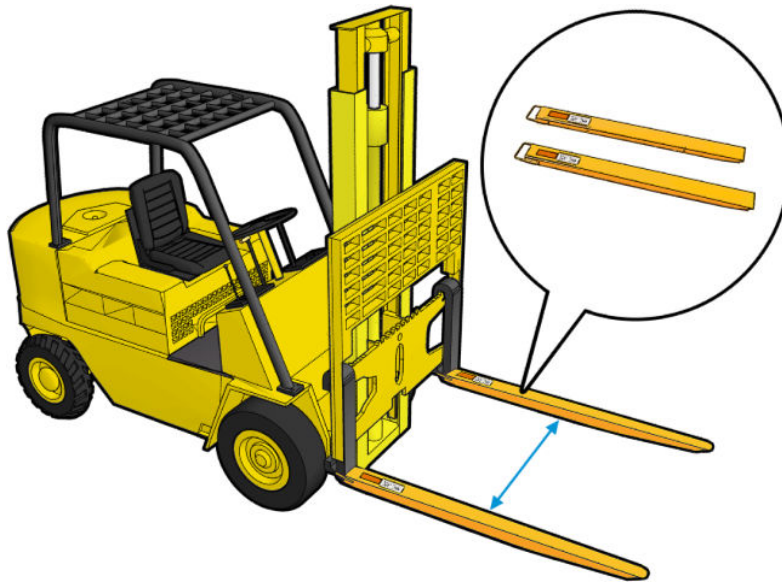

- Two skates to move the crate (optional)

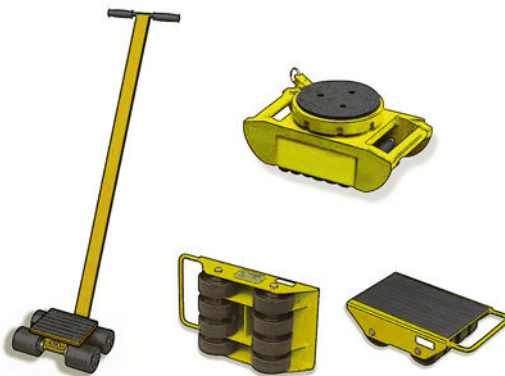

- Pallet jack (electric or manual)

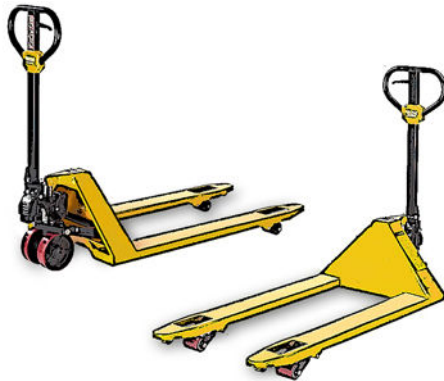
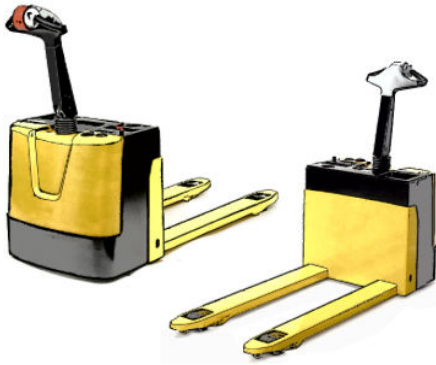

Above ground floor installation

CAUTION: Unloading and moving the printer and all system components is the responsibility of the customer and not HP. Failure to provide the required moving and lifting equipment could result in personal injury or damage the printer during installation.

Above ground floor installation requires a crane and special lifting gear in addition to the standard moving equipment. At some installation sites, it may be necessary to remove the crate packaging before lifting the printer with the crane. The following section describes the equipment and configurations needed to lift the printer with a crane.

Crane attachment to lift the printer with a spreader beam

When you lift the printer with a spreader beam, the lifting bars and spreader beam must be long enough so that the lift cables do not touch the printer. The following graphic illustrates how to lift the printer with a spreader beam.

CAUTION: When lifting the printer with a crane, extra caution should be taken to ensure that the cables do not apply pressure to the scan beam, scan axis belt, or any other printer component.

Lifting bars must be inserted under the corresponding location (labeled) on the bottom beams, and then attached to a spreader beam with cables (slings) in order to lift with a crane.

Lifting bars must remain steady on their marked position under any elevation conditions. Additional means (such as extra slings or clamps) may be required to meet this condition.

NOTE: The lifting bars, spreader beam, slings, or any other crane attachment, must be supplied by the customer.

CAUTION: The printer weight is not evenly distributed, and it may tilt to the right side.

NOTE: The printer will bend as you lift it.

When you lift the printer with a spreader beam, the lifting bars and spreader beam must be long enough so that the lift cables do not touch the printer.

The following image illustrates how to lift the printer with a spreader beam:

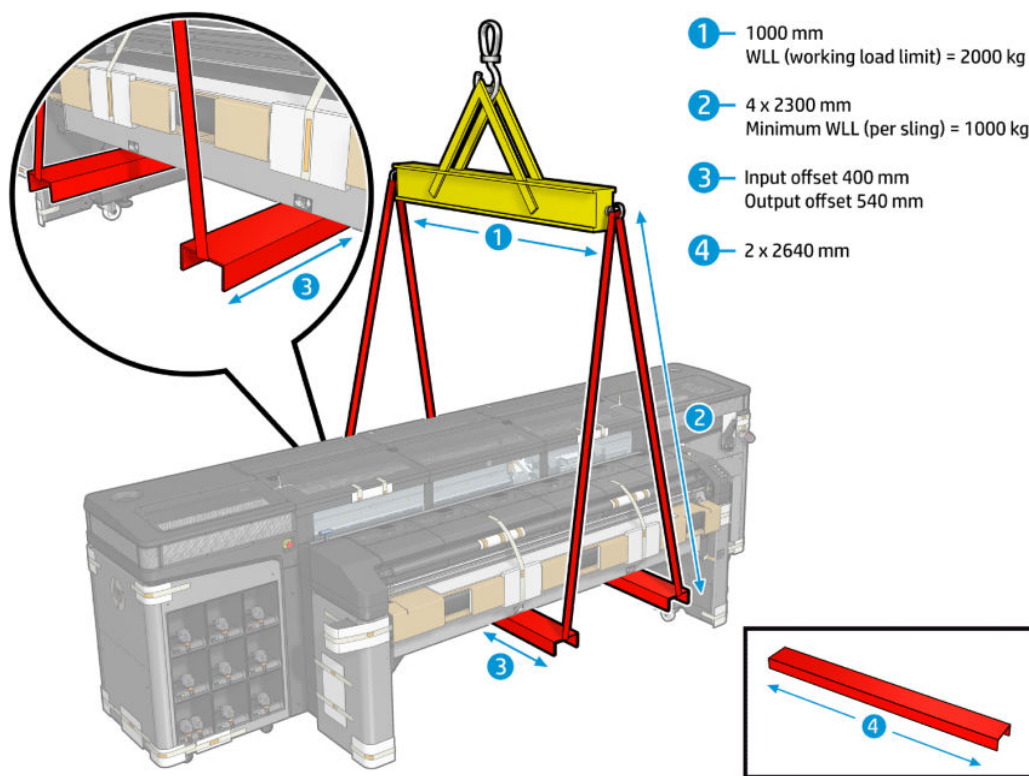

Number	Description	Requirements
1	Spreader beam	Working load limit (WLL): 2000 kg (4409 lb) Length: 1000 mm (39.4 in)
2	Slings (4)	Minimum WLL (per sling): 1000 kg (2205 lb) Minimum length: 2300 mm (90.6 in)
3	Lifting bar input and output offset	400 mm (15.7 in) (at each side)
4	Lifting bars (2)	2640 mm (104 in)

It is mandatory to position (four) eyebolts 50 mm from each end of the 2 lifting bars. The eyebolt type must be according to the WLL of each sling (1000 kg).

It is prohibited to use eyebolts directly screwed to the lifting bar.

⚠ WARNING! Make sure that the profiles are placed exactly below the stickers on the printer structure when the crane starts to raise the printer. If not, restart the procedure, as printer stability may be compromised.

Recommended profiles for the lifting bars:

Standard	Profile	Type
EU	UPE 160	A
	UPN 160	B
UK	PFC150x75x18	A

Standard	Profile	Type
	CH178x76x21	B
USA	MC150x22,5	B

Waste disposal

Printer packaging can be reused for moving the printer at a later date.

The crate and packaging material that comes with the printer can also be disposed of. Most of the waste will be wood materials. Consult with your local authorities to determine the correct manner in which to dispose of waste.

4 Site Preparation Checklist

Instructions

Complete the following address information, contact information, and checklist. If a checklist item cannot be completed or is unnecessary, add a short explanation under 'Comments'. Once you have completed the checklist, sign it and send it to your reseller or HP sales representative a minimum of two weeks before the delivery date.

 **NOTE:** Some checklist items are marked '(Required)', which means that you cannot proceed with installation until you have checked the 'Yes' box.

When you sign this document, you are confirming that the site has been prepared according to the specifications provided in the site preparation guide, that all checklist items have been completed, and that the site is prepared and ready for delivery and installation.

Checklist

Address information

Company name	Postal code
Street address	Telephone
City	Fax
Country	E-mail

Contact persons

Name

Telephone

Email

Company engineer or technician

System administrator

Operators to be trained on printer use and maintenance

Printer

HP Latex R1000 Printer (64")	<input type="checkbox"/>
HP Latex R2000 Printer (98")	<input type="checkbox"/>

General access & equipment unloading

Yes

No

Comments

Is there an easily accessible unloading area, with sufficient space to unload and maneuver the equipment?

General access & equipment unloading	Yes	No	Comments
Has the route to the installation area been checked to meet all requirements (height, width, and clearance of ceilings, doorways, ramps, and corridors) and is the conveyance route clear?	<input type="checkbox"/>	<input type="checkbox"/>	
Is a power outlet available near the site where you plan to disassemble the crate (for the electric screwdriver used to disassemble the crate)?	<input type="checkbox"/>	<input type="checkbox"/>	
Have specialist movers been contracted to unload and move the equipment on the date required?	<input type="checkbox"/>	<input type="checkbox"/>	
Are the specialist movers aware of the specifications provided in this document?	<input type="checkbox"/>	<input type="checkbox"/>	
Is there enough space and manpower required to download the printer with the ramps?	<input type="checkbox"/>	<input type="checkbox"/>	
If a forklift is needed to unload the printer, has a suitable one been contracted for installation?	<input type="checkbox"/>	<input type="checkbox"/>	
Are there skates available to help position the crate?	<input type="checkbox"/>	<input type="checkbox"/>	
Is there a pallet jack available to help position the crate?	<input type="checkbox"/>	<input type="checkbox"/>	(Optional)
Will you install the printer on a second level or higher? If so, is there a suitable crane contracted for installation? Are the appropriate crane attachments available?	<input type="checkbox"/>	<input type="checkbox"/>	
Will the operator be available for the full amount of time required for the installation training (2 days)?	<input type="checkbox"/>	<input type="checkbox"/>	

Room layout and flooring	Yes	No	Comments
Is there sufficient space around the equipment?	<input type="checkbox"/>	<input type="checkbox"/>	
Has all room construction and painting been completed?	<input type="checkbox"/>	<input type="checkbox"/>	
Does the floor load-bearing capacity meet the specifications in the site preparation guide?	<input type="checkbox"/>	<input type="checkbox"/>	
Does the floor surface meet the specifications in the site preparation guide? If special reinforcements are necessary, are they completed?	<input type="checkbox"/>	<input type="checkbox"/>	

Safety requirements	Yes	No	Comments
Is there an emergency exit in the print production area, with easy access and free from any obstruction?	<input type="checkbox"/>	<input type="checkbox"/>	
Have the two fire extinguishers been fitted in the prescribed locations in the print production and storage areas? Is the print production fire extinguisher rated for electrical fire?	<input type="checkbox"/>	<input type="checkbox"/>	
Have strategic locations been allocated for the fixture and display of the appropriate safety warning signs?	<input type="checkbox"/>	<input type="checkbox"/>	
Does the area meet the Restricted Access Location requirements in the zone surrounding the printer?	<input type="checkbox"/>		(Required)
Do the users who operate the printer have appropriate technical training and experience necessary to be aware of the hazards to which they may be exposed in performing a task and to take appropriate measures to minimize the risks?	<input type="checkbox"/>		(Required)
Will printer operations be supervised at all times?	<input type="checkbox"/>		(Required)

Electrical installation	Yes	No	Comments
Has the site been prepared for the chosen power option?			
Configuration 1 branch circuit breaker: 4 poles, 40/50 A	<input type="checkbox"/>		
Configuration 2 branch circuit breaker: 3 poles, 63/70 A	<input type="checkbox"/>		
Configuration 3 branch circuit breaker:			
• Three-phase: 4 poles, 40/50 A	<input type="checkbox"/>		(Required)
• Two-phase control: 2 poles, 15/16/20 A	<input type="checkbox"/>		
Configuration 4 branch circuit breaker:			
• Three-phase: 3 poles, 63/70 A	<input type="checkbox"/>		
• Two-phase control: 2 poles, 15/16/20 A	<input type="checkbox"/>		
Is the chosen power system within its nominal range?			
Configuration 1	<input type="checkbox"/>		
Configuration 2	<input type="checkbox"/>		(Required)
Configuration 3	<input type="checkbox"/>		
Configuration 4	<input type="checkbox"/>		
Is the grounding conductor properly installed, as shown in the site preparation guide?	<input type="checkbox"/>		(Required)
Have you booked the services of an electrician for the day of installation?	<input type="checkbox"/>		(Required)
Is the electrician aware of all requirements and specifications highlighted in this document?	<input type="checkbox"/>		(Required)
Is the Power Distribution Unit (PDU) correctly installed?	<input type="checkbox"/>		(Required)
Are Residual-Current Circuit Breakers (RCCB), also known as Ground Fault Circuit Interrupters (GFCI), required by local laws? if so, have they a sensitivity of 100 mA or higher?	<input type="checkbox"/>	<input type="checkbox"/>	

Electrical configuration	Yes	No	Comments
Do you need an Uninterrupted Power Supply (UPS)? If so, is it correctly installed?	<input type="checkbox"/>	<input type="checkbox"/>	
No power cords are supplied with the printer; does the electrician understand that power cord(s) must be provided according to printer specifications and local laws?	<input type="checkbox"/>	<input type="checkbox"/>	
If local regulations specify that you must use electrical plugs to connect the printer to the power supply, does the electrician have the required plugs ready for installation?	<input type="checkbox"/>	<input type="checkbox"/>	

Networking requirements	Yes	No	Comments
Have network connections been supplied?	<input type="checkbox"/>	<input type="checkbox"/>	
Do you have a LAN cable long enough to connect the printer to the network?	<input type="checkbox"/>	<input type="checkbox"/>	
Do you have an Internet connection?	<input type="checkbox"/>	<input type="checkbox"/>	

Equipment preparation	Yes	No	Comments
Is the air compressor or pressurized air line ready for the day installation?	<input type="checkbox"/>	<input type="checkbox"/>	
Have the correct supplies been ordered for deliver on or before the date of the printer's installation? Minimum requirements: One set of ink cartridges and 10 l of distilled water Recommended: One set of ink cartridges, an extra set of ink cartridges, and the correct substrate for training purposes: six sheets of corrugated plastic (fluted) or similar, 70 × 100 cm (27.6 × 39.4 in) or larger	<input type="checkbox"/>	<input type="checkbox"/>	

RIP requirements	Yes	No	Comments
Has the HP Scitex ONYX Thrive RIP v12.1 (or later) software (D9Z41A) been ordered, and is the computer to be used available with the required specifications?	<input type="checkbox"/>	<input type="checkbox"/>	
Has the HP Scitex Caldera Grand RIP v11.1 (or later) software (L5E74A) been ordered, and is the computer to be used available with the required specifications?	<input type="checkbox"/>	<input type="checkbox"/>	
If neither of the HP Scitex RIPs is to be used, is there a computer available with a RIP application installed that supports the printer?	<input type="checkbox"/>	<input type="checkbox"/>	
Do you have a spectrophotometer that is compatible with the RIP?	<input type="checkbox"/>	<input type="checkbox"/>	

Environmental requirements	Yes	No	Comments
Have the temperature and humidity requirements been satisfactorily met in the print production area, and is there adequate ventilation or air conditioning?	<input type="checkbox"/>	<input type="checkbox"/>	
Have the temperature and humidity requirements been satisfactorily met in the storage area?	<input type="checkbox"/>	<input type="checkbox"/>	
Is the print production area free from dirt and dust?	<input type="checkbox"/>	<input type="checkbox"/>	
Does the print production area have sufficient lighting?	<input type="checkbox"/>	<input type="checkbox"/>	
Have you met or exceeded all the requirements specified in the site preparation guide?	<input type="checkbox"/>		(Required)
Have you met or exceeded all the ventilation and air conditioning requirements: <ul style="list-style-type: none"> • 120 m³ (4238 ft³) HP Latex R1000 Printer • 185 m³ (6533 ft³) HP Latex R2000 Printer ...or met the requirements for special room sizes?	<input type="checkbox"/>	<input type="checkbox"/>	
Are you aware of the training available for the printer?	<input type="checkbox"/>	<input type="checkbox"/>	

Date of site preparation completion

Site preparation guide edition number or copyright date

Customer signature

Materials and applications	Yes	No	Comments
Do you have the substrate edge holders?	<input type="checkbox"/>	<input type="checkbox"/>	

Materials and applications	Yes	No	Comments
Acrylic sheet (PMMA)	<input type="checkbox"/>	<input type="checkbox"/>	
Aluminum composite (ACP)	<input type="checkbox"/>	<input type="checkbox"/>	
Compressed cardboard or cardstock (edge holders recommended)	<input type="checkbox"/>	<input type="checkbox"/>	
Corrugated cardboard (edge holders recommended)	<input type="checkbox"/>	<input type="checkbox"/>	
Corrugated plastic	<input type="checkbox"/>	<input type="checkbox"/>	
Foam board	<input type="checkbox"/>	<input type="checkbox"/>	
Foam PVC	<input type="checkbox"/>	<input type="checkbox"/>	
Glass and Ceramics	<input type="checkbox"/>	<input type="checkbox"/>	
Wood	<input type="checkbox"/>	<input type="checkbox"/>	
Polycarbonate sheet	<input type="checkbox"/>	<input type="checkbox"/>	
Polystyrene sheet	<input type="checkbox"/>	<input type="checkbox"/>	
Polystyrene foam board	<input type="checkbox"/>	<input type="checkbox"/>	
Polypropylene sheet	<input type="checkbox"/>	<input type="checkbox"/>	
PVC rigid sheet (U-PVC)	<input type="checkbox"/>	<input type="checkbox"/>	
PET (A-PET, PET-G) rigid sheet	<input type="checkbox"/>	<input type="checkbox"/>	
PE (LDPE, HDPE) rigid sheet	<input type="checkbox"/>	<input type="checkbox"/>	
Honeycomb panels	<input type="checkbox"/>	<input type="checkbox"/>	
Metal panels	<input type="checkbox"/>	<input type="checkbox"/>	
Self-Adhesive Vinyls	<input type="checkbox"/>	<input type="checkbox"/>	
PVC Banners	<input type="checkbox"/>	<input type="checkbox"/>	
Papers	<input type="checkbox"/>	<input type="checkbox"/>	
Textiles	<input type="checkbox"/>	<input type="checkbox"/>	
Flexible films	<input type="checkbox"/>	<input type="checkbox"/>	
Other materials (to fill in)	Yes	No	Comments
	<input type="checkbox"/>	<input type="checkbox"/>	
	<input type="checkbox"/>	<input type="checkbox"/>	
	<input type="checkbox"/>	<input type="checkbox"/>	
	<input type="checkbox"/>	<input type="checkbox"/>	
	<input type="checkbox"/>	<input type="checkbox"/>	
	<input type="checkbox"/>	<input type="checkbox"/>	
	<input type="checkbox"/>	<input type="checkbox"/>	
	<input type="checkbox"/>	<input type="checkbox"/>	
	<input type="checkbox"/>	<input type="checkbox"/>	
	<input type="checkbox"/>	<input type="checkbox"/>	

Materials and applications	Yes	No	Comments
Which applications do you plan to use?			
Outdoor temporary signage	<input type="checkbox"/>		
Outdoor permanent signage	<input type="checkbox"/>		
Decoration	<input type="checkbox"/>		
Indoor signage (panels and FSDU)	<input type="checkbox"/>		
Window graphics	<input type="checkbox"/>		
Other applications (to fill in)			
	<input type="checkbox"/>		
	<input type="checkbox"/>		
	<input type="checkbox"/>		
	<input type="checkbox"/>		
	<input type="checkbox"/>		
	<input type="checkbox"/>		